

SELECTSET AVANTRA USER GUIDE

A Guide to Your Drum Laser Imagesetter

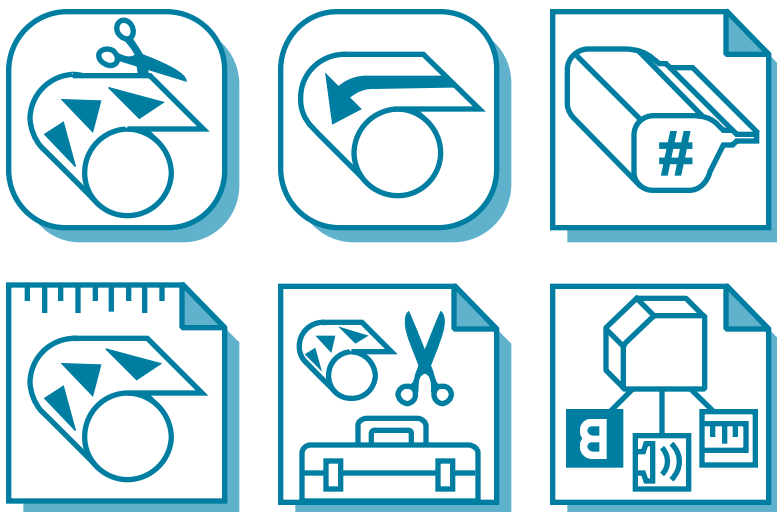

Part Number
209602-001

**FEDERAL COMMUNICATIONS COMMISSION
RADIO FREQUENCY INTERFERENCE STATEMENT**

NOTE: This equipment has been tested and found to comply with the limits for a Class A digital device, pursuant to Part 15 of the FCC Rules. These limits are designed to provide reasonable protection against harmful interference when the equipment is operated in a commercial environment. This equipment generates, uses, and can radiate radio frequency energy and, if not installed and used in accordance with the instruction manual, may cause harmful interference to radio communications. Operation of this equipment in a residential area is likely to cause harmful interference in which case the user will be required to correct the interference at his own expense.

CAUTION: Only computers and other peripheral devices which as a minimum comply with Class A limits should be used with this equipment. Shielded I/O cables should be used for equipment connections in order to ensure FCC emission limits are met. Any changes or modifications to this equipment not expressly approved by Agfa Division, Miles Inc. could void the user's authority to operate the equipment.

**CANADIAN RADIO INTERFERENCE
REGULATIONS STATEMENT**

This digital apparatus does not exceed the Class A limits for radio noise emissions from digital apparatus set out in the Radio Interference Regulations of the Canadian Department of Communications.

Le présent appareil numérique n'émet pas de bruits radioélectriques dépassant les limites applicables aux appareils numériques (de la class A) prescrites dans le Règlement sur le brouillage radioélectrique édicté par le ministère des Communications du Canada.

SELECTSET AVANTRA USER GUIDE

A Guide to Your Drum Laser Imagesetter

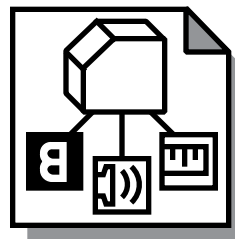
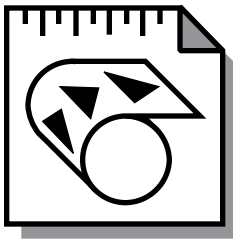
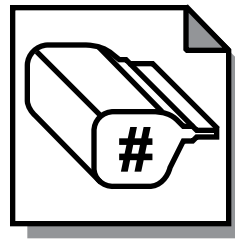

Part Number
209602-001

AGFA 

Note to Users

Agfa Division, Miles Inc. (also referred to as “Agfa”) reviews all customer documentation and software for accuracy before shipment. Occasionally, in spite of precautions, the product you receive may differ somewhat from the customer documentation shipped to you. Generally, if such variations are known to exist and to significantly affect operation, a release note accompanies the documentation or software. If you receive such a note, be sure to read it before using the product.

Copyright © 1993 by Miles Inc. All rights reserved.

No part of this publication may be reproduced, transmitted, transcribed, stored in a retrieval system, or translated into any language or computer language, in any form or by any means, whether electronic, mechanical, magnetic, optical, chemical, or manual, without prior written permission from Agfa Division, Miles Inc., 200 Ballardvale Street, Wilmington, Massachusetts 01887.

Disclaimer

This document was prepared by Customer Documentation, Agfa Division, Miles Inc. Illustrations are meant to be representative of, but not duplicates of, actual equipment and software. Agfa shall not be responsible for any errors or omissions. Please report any errors to Customer Documentation, Agfa Division, Miles Inc., 200 Ballardvale Street, Wilmington, Massachusetts 01887.

AGFA MAKES NO REPRESENTATIONS OR WARRANTIES WITH RESPECT TO THE CONTENTS OF THIS DOCUMENT OR THE SOFTWARE DESCRIBED IN THIS DOCUMENT, ITS QUALITY, OR PERFORMANCE, AND SPECIFICALLY DISCLAIMS ANY IMPLIED WARRANTIES OF MERCHANTABILITY OR FITNESS FOR ANY PARTICULAR PURPOSE. Agfa reserves the right to revise this document and to change the contents without any obligation to notify any person of such revision or changes.

Trademarks

AGFA and the Agfa rhombus are registered trademarks of Agfa-Gevaert N.V. Agfa is a registered trademark, SelectSet and Avantra are trademarks of Miles Inc. PostScript is a trademark of Adobe Systems Incorporated which may be registered in certain jurisdictions.

Other brand or product names are trademarks or registered trademarks of their respective holders and have been used in an editorial fashion with no intention of infringement.

Colophon

The following typefaces appear in this document:

- Text Bookman
- Headings Helvetica* Bold
- Captions Helvetica Light Oblique

*Helvetica is a trademark of Linotype AG and/or its subsidiaries.

Table of Contents

Preface

Purpose.....	xv
Audience	xv
Overview	xvi
How to Use this Guide	xvii
Other Manuals	xviii

Chapter 1: Getting Acquainted

Introduction	1-1
Parts of the Imagesetter.....	1-2
Media Compartment	1-2
Main Power Switch	1-2
The Control Panel	1-4
Specifications and Features.....	1-5
Options	1-6
Your Imaging System.....	1-8
Raster Image Processors	1-8

Safety Information.....	1-9
Laser Information	1-9
Laser Safety Instructions	1-10
General Safety Instructions.....	1-11
Sound Level.....	1-12
Labeling.....	1-12

Chapter 2: Basic Control Panel Operations

Introduction	2-1
Start Up and Shut Down Procedures	2-2
Shut Down Procedure.....	2-3
About the Control Panel	2-3
Control Panel Screens	2-4
Basic Controls.....	2-6
Special Features of Plus and Minus	2-7
Special Features of Accept and Cancel	2-7
Using Functions	2-8
Select a Screen	2-8
To Set a Parameter	2-9
Press Some Buttons Twice	2-11
Buttons Display Current Setting.....	2-11

Chapter 3: Using the Control Panel

Introduction	3-1
The Run Screen.....	3-2
Operating Modes.....	3-2
Progress Bar	3-2
Current Job Information	3-3
Pause Pending	3-3
The Pause Screen	3-4
Load a Media Supply	3-5
Feed and Cut.....	3-5
Unload.....	3-6
Display Job History	3-7
Run and Pause Status Icons.....	3-8
Media Status	3-8
Engine Status.....	3-11
Job Status.....	3-13
Supply Alarm.....	3-14
Take-up Alarm.....	3-15

The Cassette Setup Screen	3-16
Exposure Settings.....	3-18
Cassette Parameters	3-19
Specifying a Cassette Number.....	3-20
List of Cassette Parameters.....	3-21
The Feed Amounts Screen	3-22
Definitions	3-23
The Utilities Screen	3-24
To Use Utilities Functions.....	3-25
Definitions	3-25
The Configuration Screen	3-26
Definitions	3-27
Image Mode	3-28

Chapter 4: Media Operations

Introduction	4-1
Loading Media into Supply Cassettes.....	4-2
Installing Loaded Supply Cassettes.....	4-6
Removing Supply Cassettes	4-9

Take-up Cassettes	4-11
Removing Take-up Cassettes	4-11
Inserting Take-up Cassettes.....	4-12
Opening and Closing the Media Slot.....	4-13

Chapter 5: Exposure Tests

Introduction	5-1
The Test Page	5-2
The 4 DPI's Test Page.....	5-4
Running Exposure Tests	5-5
When to Image a Test Page	5-5
How to Image an Exposure Test Page.....	5-6
Reading a Test Page.....	5-8
Evaluating Test Pages.....	5-10
Densitometers	5-10
Set the Exposure	5-10

Chapter 6: Diagnostics and Error Messages

Introduction	6-1
Error Procedures.....	6-2
Clearing Errors	6-2
Resetting	6-2

Error Messages	6-3
Special Error Procedures	6-15
Unload Media Using the Utility Screen	6-15
Overriding Error 44: Cut Not Allowed	6-16
Remote Diagnostics	6-17
Boot Errors	6-18
Bypassing Boot Errors	6-19

Chapter 7: Maintenance and Troubleshooting

Introduction	7-1
Clearing Media Jams	7-2
Remove Nip Drive Assembly	7-2
Clear Media from Drum: Access from the Left	7-5
Clear Media from Drum: Access from the Right	7-7
Clear Media from Input Side	7-9

Maintenance	7-11
Exterior	7-12
Interior	7-12
Supply Cassettes	7-12
Take-up Cassettes	7-12
Supply Rollers	7-13
Intake Filters	7-14
Punch Trays	7-15

Chapter 8: Avantra 20/25 OLP Bridge Operation

Introduction	8-1
Product Description.....	8-2
Set Up the Processor Option.....	8-4
Special Points to Remember.....	8-5
Bridge Operating Sequence.....	8-6
To Optimize Output	8-7
Clearing the Bridge Media Path	8-8
Removing the Bridge Access Panels.....	8-8
Bypassing the Bridge.....	8-10

Chapter 9: Avantra 20/25 OLP Processor Operation

Introduction	9-1
Processor Description	9-2
Starting the Processor	9-2
The Processor Control Panel	9-3
Idle State	9-4
Run State	9-4
Alarm Signals	9-5
Status Signals	9-5
Function Keys	9-5
Automatic Functions	9-6
Jog Function	9-6
Automatic Start and Stop	9-6
System Clock	9-7
Changing the Time	9-8
Auto On/Off	9-9
Select On/Off Mode, Display On/Off Time	9-9
Setting On and Off Time	9-10
Checking the On/Off Selection	9-11
Checking Preset Values	9-12
Changing the Developer Time	9-13
Changing Temperature	9-14

Changing Replenishment Rates	9-15
Standby Replenishment.....	9-16
Other Functions	9-17
Sound.....	9-17
Pan Light	9-17
Dryer Saver	9-18
Man. Repl.	9-18
Man. Start	9-18
Density 15%, 50%, 85%.....	9-19
Offline Operation.....	9-20
Programming.....	9-21
Selecting Programs	9-21
Revising Programs	9-21
Processor Maintenance.....	9-23
Daily Maintenance.....	9-23
Weekly Maintenance	9-24
Monthly Maintenance	9-27
Switches and Sensors.....	9-29
Processor Status and Error Messages	9-29

Appendix A: Image Quality

Introduction.....	A-1
Importance of Optimum Exposure	A-1
Definitions	A-2
Density.....	A-2
Dmax	A-2
Exposure	A-3
Development	A-3
Replenishment	A-4
Guidelines for Quality	A-5

Appendix B: Tips and Tricks

Introduction.....	B-1
Using Plate Material	B-2
Switching Media Supplies	B-6
Processor Replenishment	B-8
Automatic Replenishment.....	B-8
STDBY Replenishment	B-9
Manual Replenishment.....	B-9
Minimum and Maximum Settings.....	B-10

Appendix C: RIP User Tools

Introduction.....	C-1
RIP User Tools Defined.....	C-2
RIP Tools Match Control Panel Functions	C-2
User Tools Charts	C-3
Pause	C-3
Cassette Setup	C-3
Feed Amounts	C-4
Configuration	C-5
Special Tools	C-5
SelectSet Avantra Special Tools.....	C-6
Virtual Cassette Operating Mode	C-6
Media Optimization	C-7

Index

Preface

Purpose

This guide describes how to operate the SelectSet™ Avantra™ family of internal drum laser imagesetters.

Audience

This guide is written for operators who are familiar with:

- Basic concepts of desktop publishing.
- Operation of the software applications, computers, and other hardware in use with their imagesetter.
- Operation of the RIP that drives the SelectSet Avantra.

This basic knowledge is critical to the effective and successful operation of this imagesetter.

Overview

Chapter 1: Getting Acquainted

Features, options, parts of the imagesetter, safety information.

Chapter 2: Basic Control Panel Operations

Startup procedure, features of the control panel, basic description of the control panel screens, how you perform different functions at the control panel.

Chapter 3: Using the Control Panel

Detailed description of the six control panel screens and how to use them. Also describes the status icons that appear on the control panel.

Chapter 4: Media Operations

Use of supply cassettes; filling them with media, inserting and removing them from the imagesetter. How to insert and remove take-up cassettes.

Chapter 5: Exposure Tests

How to perform and evaluate exposure tests using the test page files that are part of the SelectSet Avantra software.

Chapter 6: Diagnostics and Error Messages

Definitions of the different error messages that appear on the control panel screen and corrective action. Accessing a remote diagnostic device. Boot errors and how to recover from them.

Chapter 7: Maintenance and Troubleshooting

Basic maintenance procedures for the imagesetter, procedures for clearing media jams.

Chapter 8: Avantra 20/25 OLP Bridge Operation

Overview of the Avantra 20/25 OLP, setting up the imagesetter to use the on-line processor, how the bridge works, how to bypass the bridge, and how to clear media jams in the bridge.

Chapter 9: Avantra 20/25 OLP Processor Operation

Describes the operation of the on-line media processor, how to set time, temperature, replenishment rates and other parameters, using the processor off-line, maintenance procedures.

Appendix A: Image Quality

Information about the photographic principles used by the SelectSet Avantra family of imagesetters.

Appendix B: Tips and Tricks

Applications information to help you use the SelectSet Avantra more effectively.

Appendix C: RIP User Tools

Information about RIP user tools designed specifically for use with SelectSet Avantra imagesetters. These tools are provided with your Agfa RIP.

How to Use this Guide

Read *Chapter 1: Getting Acquainted* before you begin to use your SelectSet Avantra imagesetter.

Read *Chapter 8: Avantra 20/25 OLP Bridge Operation* and *Chapter 9: Avantra 20/25 OLP Processor Operation* before you use the on-line processor.

The rest of the manual has been prepared to be both a training and reference guide, to be used as needed.

This guide assumes that you are familiar with the operation of all the other parts of your imaging system.

Other Manuals

This guide is only one part of the documentation you need as you set up and operate your imagesetter. To get more information, you need to refer to other user guides and manuals.

A raster image processor, or *RIP*, drives your imagesetter. A number of different RIPs can be used with the SelectSet Avantra. Each comes with its own documentation. RIP documentation provides information about RIP user tools, fonts, and PostScript® language as it applies to the SelectSet Avantra.

Chapter 1:
Getting Acquainted

Introduction

The SelectSet Avantra imagesetter is designed for applications that require high standards of image quality and versatility.

This chapter describes the following:

- Parts of the imagesetter
- Specifications and features
- Options
- System configuration
- Safety instructions

Please read the safety information in this chapter before you operate your SelectSet Avantra. See the sections *Safety Instructions* and *Laser Safety Information* later in this chapter.

Parts of the Imagesetter

The SelectSet Avantra imagesetter is designed for ease of use. This section describes the basic components.

Media Compartment

The media compartment contains the supply cassette, the take-up cassette, and cutter.

- **Supply Cassette**
Holds unexposed media. You load it with bulk rolls of media.
- **Take-up Cassette**
Holds exposed media. A take-up cassette is supplied with the imagesetter.
- **Cutter**
Cuts media when you are ready to remove the take-up cassette to process exposed media. The cutter can be activated from either the control panel or the front end of your imaging system.

On systems equipped with the optional Avantra 20/25 OLP, the media transport bridge is installed in the media compartment.

Main Power Switch

The main power switch is located at the front of the imagesetter, to the left of the control panel. See Figure 1.1.

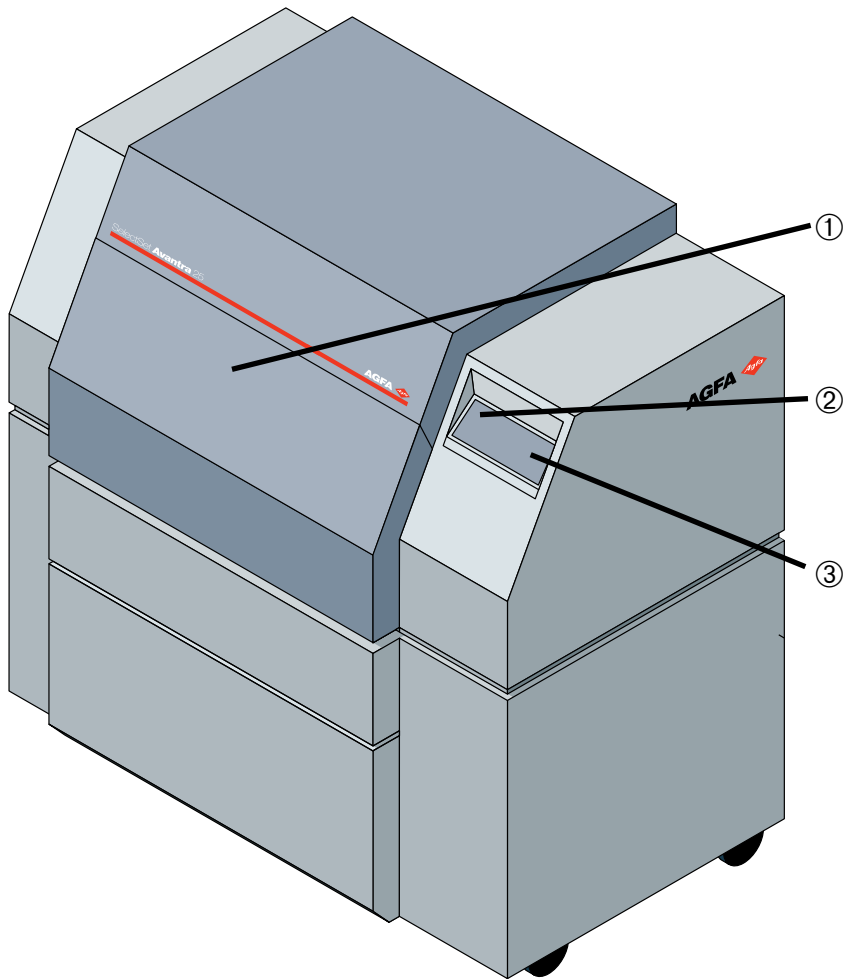

Figure 1.1. The SelectSet Avanti Imagesetter.

①—Media compartment. ②—Main power switch. ③—Control panel

The Control Panel

The control panel is a liquid crystal display (LCD) with a pressure sensitive surface. *Status icons* on the screen display information about the imagesetter. Some icons act as buttons. You press these *button icons* to operate the imagesetter. See Figure 1.2.

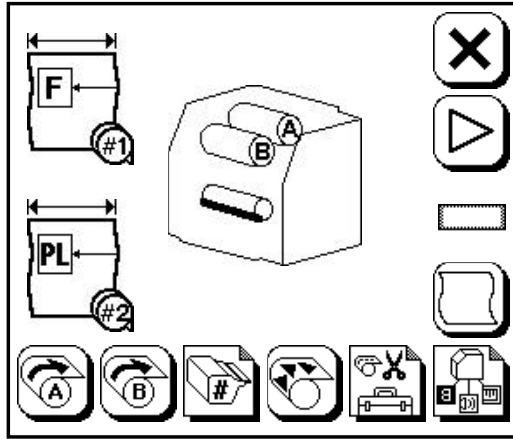

Figure 1.2. The SelectSet Avantra control panel showing the Pause Screen.

Specifications and Features

The following table shows the basic specifications of the SelectSet Avantra 20 and the SelectSet Avantra 25.

	SelectSet Avantra 20	SelectSet Avantra 25
Format Size	14" x 20" 35.6 x 50.8 cm	18" x 25" 45.7 x 63.5 cm
Resolutions	1200, 1800, 2400, 3600 dpi	1200, 1800, 2400, 3600 dpi
Imaging Speed	340 sq. in./min. @ 1200 dp	400 sq.in./min. @ 1200 dpi
Registration	0.2 mils (5 μ)	0.2 mils (5 μ)

Both SelectSet Avantra models include these features:

- **Icon based control panel**
The control panel uses a series of graphic pictures to show system status and functions.
- **Multiple laser spot sizes**
Laser spot size optimized for each imaging resolution.
- **Memory for cassette parameters**
Cassette parameters include the media type, exposure values, media width, media remaining. The system stores the settings you enter for each cassette.
- **Internal drum imaging system**
Yields the precise registration required to image multi-color jobs.
- **Reloadable supply cassette**
The SelectSet Avantra uses a reloadable supply cassette that accepts daylight loading or darkroom loading media.
- **Media Optimization**
You can program the imagesetter to rotate jobs for most efficient use of media.

Options

These extra-cost options are available:

- **Avantra 20/25 OLP**
A media processor and media transport bridge that attach to the imagesetter. With the OLP, you can program the imagesetter to advance and cut exposed media, then send it through the bridge to the processor to be developed.
- **DualSupply Option**
Can be equipped with a dual media supply. Load two different types of media for fast-changing job requirements.
- **FlexMedia Option**
Fine tunes the imagesetter to a wide range of media widths and thicknesses. Includes OptiFocus (adjustable focus lens) and media width adjustment.
- **Registration Punch Option**
Enables punching of media to facilitate registration of multicolor jobs.
- **Upgrade Option**
The SelectSet Avantra 20 can be upgraded to a SelectSet Avantra 25. All options are available to systems that have been upgraded.
- **Extra Cassettes**
Extra media supply cassettes and take-up cassettes can help you operate more efficiently. For example, you might choose to purchase a separate supply cassette for each type of media that you use.

The following table lists the extra-cost options:

Option	SelectSet Avantra 20	SelectSet Avantra 25
On Line Processor	Yes	Yes
DualSupply	N/A	Yes
FlexMedia	N/A	Yes
Registration Punches:		
Head Punch	Stoesser only	Stoesser or Bacher
Tail Punch	N/A	Stoesser or Bacher
Custom	N/A	Yes
Upgrade Option	Yes	N/A

Your Imaging System

Your SelectSet Avantra is one component of a complete imaging system. Imaging systems can include:

- Front end computers running PostScript language applications software. These are used for word processing, creation and editing of graphic images and page layout.
- A raster image processor (RIP). This receives the job from the front end, reassembles it, and sends it to the imagesetter.
- Output devices. Includes proofing devices driven from the front end computer and high-quality final production devices such as the SelectSet Avantra imagesetter, driven by their own RIPs.

Imaging systems that support SelectSet Avantra imagesetters can be made up of many different combinations of hardware and software. To use your imagesetter most effectively, you need to understand all the components of your unique imaging system.

Raster Image Processors

The SelectSet Avantra imagesetter is driven by a RIP (raster image processor). The RIP performs two functions:

1. It interprets the data generated by applications running on the front end of your imaging system.
2. It converts this data to a form that can be used by the imagesetter.

The SelectSet Avantra can be used with a wide choice of software and hardware RIPs.

- Software RIPs run on standard computer platforms. These standard platforms can serve other functions when not used as RIPs.
- Hardware RIPs are computers designed to function only as RIPs.

Safety Information

This section provides safety information about the SelectSet Avantra.

- *Laser information:* Information about the laser device used within the imagesetter and the laser radiation that it emits.
- *Laser safety instructions:* Specific instructions for safe operation of this laser imagesetter.
- *General safety instructions:* Guidelines for safe operation of this laser imagesetter.
- *Sound level:* States the sound level at the operator's position and the method used to measure it.
- *Labeling:* A description of the different safety and warning labels that are attached to the SelectSet Avantra.

Laser Information

The SelectSet Avantra imagesetters are classified as Class I laser devices. The maximum accessible radiation level during operation and maintenance is less than Class I limits. This means that you are not exposed to any hazardous laser radiation during operation and maintenance. The SelectSet Avantra complies with Code of Federal Regulations 21CFR, Subchapter J.

Inside SelectSet Avantra imagesetters are two Class IIIb laser products. These devices emit radiation that is considered hazardous in accordance with the Code of Federal Regulations and international standards.

You are not exposed to this level of radiation as long as protective covers remain in place and interlocks are not bypassed.

Laser Safety Instructions

WARNING

To avoid hazardous radiation exposure, follow these instructions:

- Do not use controls or adjustments other than those specified in this user guide.
- Do not perform procedures other than those specified in this user guide.
- Do not attempt to service this unit.
- Never attempt to look at the laser beam, even if the unit appears to be nonfunctioning.
- Never remove the covers or enclosures except as instructed in this user guide.

Do not remove the protective covers during operation or maintenance except as instructed in this manual. Never bypass the safety interlocks.

These covers and interlocks have warning labels located near them. Removal of covers or bypassing the interlocks may expose you to laser radiation that is considered hazardous according to Code of Federal Regulations, section 1040.10.

General Safety Instructions

1. Turn off power, then unplug the imagesetter from the wall outlet before cleaning. Use only a damp cloth. Do not use liquid or aerosol cleaners.
2. Do not use the imagesetter in any area near water.
3. Keep all liquids off the top of the imagesetter to prevent spills.
4. Slots and openings in the enclosure provide ventilation. To ensure reliable operation, these openings must not be blocked. Install the imagesetter at least 12 inches (31 cm) away from walls. (Optimum clearance is 24 inches or 61 cm.) Do not place objects between the imagesetter and the wall.
5. Make sure that the imagesetter is connected to the correct power source. This information is indicated on the model tag.
6. The imagesetter must be electrically grounded to ensure conformance to safety requirements. It is provided with a 3-wire grounding type plug, which has a grounding pin. If this plug does not fit your electrical outlet, contact your electrician to replace the obsolete outlet.
7. Never allow objects of any kind into the imagesetter through the enclosure vents. Objects may come in contact with hazardous voltage. This could create a risk of fire or electric shock.
8. Do not attempt to service the imagesetter yourself, except as specifically explained in this User Guide. Opening and removing covers may expose you to dangerous voltage and radiation hazards.
9. Unplug the imagesetter from the wall outlet and place a service call under these conditions:

The power cord is damaged or frayed.

Liquid has been spilled into the imagesetter.

The imagesetter has been physically damaged.

The imagesetter does not operate normally even when operating instructions are followed.

Sound Level

The sound level at the operators position does not exceed 66 dB(A). The measurements were done in accordance with ISO 7779.

Labeling

Various warning and compliance labels are attached to the SelectSet Avantra.

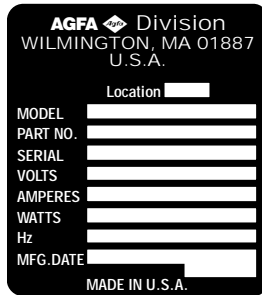

Figure 1.3. Manufacturer's identification label, located on the rear panel.

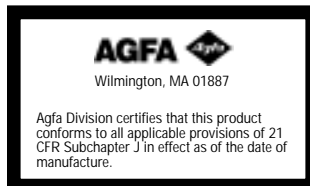

Figure 1.4. CDRH compliance label, located on the rear panel. It reads:
This product conforms to all applicable provisions of 21 CFR, subchapter J
in effect as of the date of manufacture.

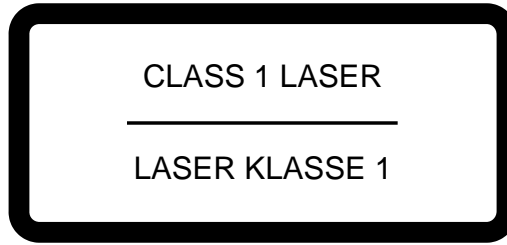

Figure 1.5. Laser class label, located on the rear panel of the unit. Indicates the class of laser radiation during operation and maintenance.

Note: Class I lasers are considered safe for operator access in accordance with the Code of Federal Regulation and international standards.

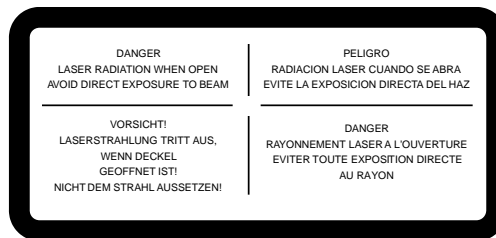

Figure 1.6. Multilingual warning label., located near the punch inside the imagesetter. It reads:

DANGER
LASER RADIATION WHEN OPEN
AVOID DIRECT EXPOSURE TO BEAM

Chapter 2:

Basic Control Panel Operations

Introduction

This chapter provides an introduction to the SelectSet Avantra control panel. It contains the following information:

- How to start and shut down the imagesetter
- Features of the control panel
- Introduction to the control panel screens
- Basic controls for use in the control panel screens
- How to perform different functions with the control panel screens

Start Up and Shut Down Procedures

Follow these steps to start the SelectSet Avantra.

Step 1: Turn on the imager. Press the green side of the switch located next to the control panel. A progress bar appears at the bottom of the screen as the imager boots up.

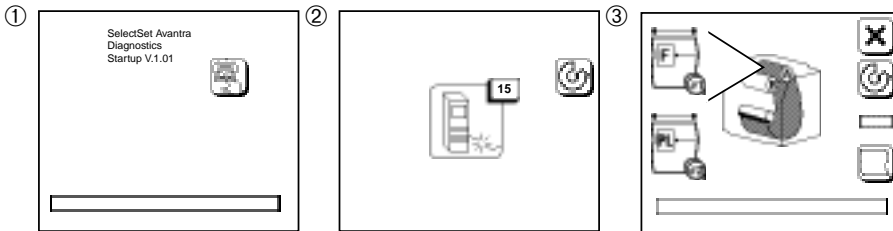

Figure 2.1. Screens that appear as you start up the SelectSet Avantra.

Step 2: When the control panel displays message 15 (No RIP), turn on the RIP. Follow the instructions in the manuals that come with your RIP.

Step 3: When both the imager and the RIP are ready, the control panel shows a display called the Run Screen.

If there is no media loaded, or if there is no take-up cassette in place, or if the bridge for the on-line processor is out of position, the Pause Screen appears instead of the Run Screen.

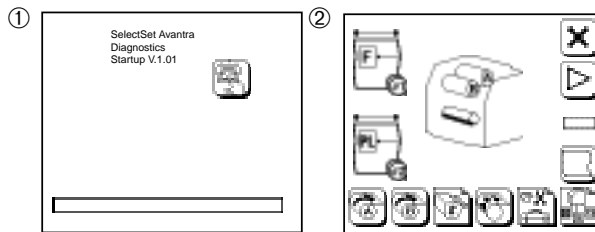

Figure 2.2. In some cases, the Pause Screen appears when you start up the imager.

Step 4: Turn on the other parts of your imaging system.

Step 5: To ensure consistent results, let the imagesetter run for twenty minutes before you begin to image jobs.

Shut Down Procedure

To shut down the imagesetter, turn off the power at the control panel.

About the Control Panel

- The control panel is a liquid crystal display (LCD).
- Graphic pictures, called *icons*, appear on the control panel.
- Icons represent objects (such as the imagesetter or an output cassette) or functions that the imagesetter performs (such as feeding media).
- The LCD is divided into pressure-sensitive squares.
- You operate the imagesetter by touching the icons that represent functions. These icons are called *buttons*.
- Pictures and numbers appear on the control panel to show the current status of the imagesetter. These are called *status icons*.
- The complete set of icons that appears on the control panel display at one time is called a *screen*.

Control Panel Screens

- There are six control panel screens.
- The Run Screen appears when you first start up the imagesetter.
- Press Pause to go to the Pause Screen.
- Press the square cornered buttons at the bottom of the Pause Screen to access the Cassette Setup, Feed Amounts, Utilities, and Configuration Screens.

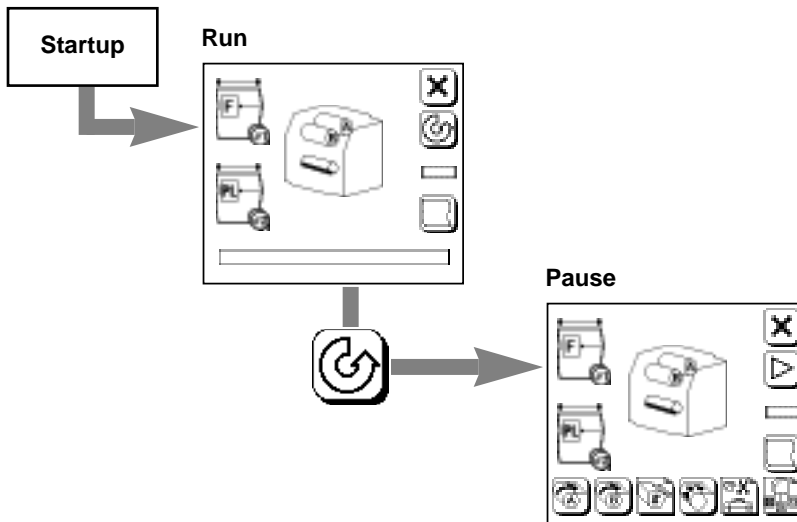

Figure 2.2. When you start up the imagesetter, the Run Screen appears.
Press Pause to go to the Pause Screen.

Note: If there is no media loaded, or if there is no take-up cassette in place, or if the bridge for the on-line processor is out of position, the Pause Screen appears instead of the Run Screen when you start up the imagesetter.

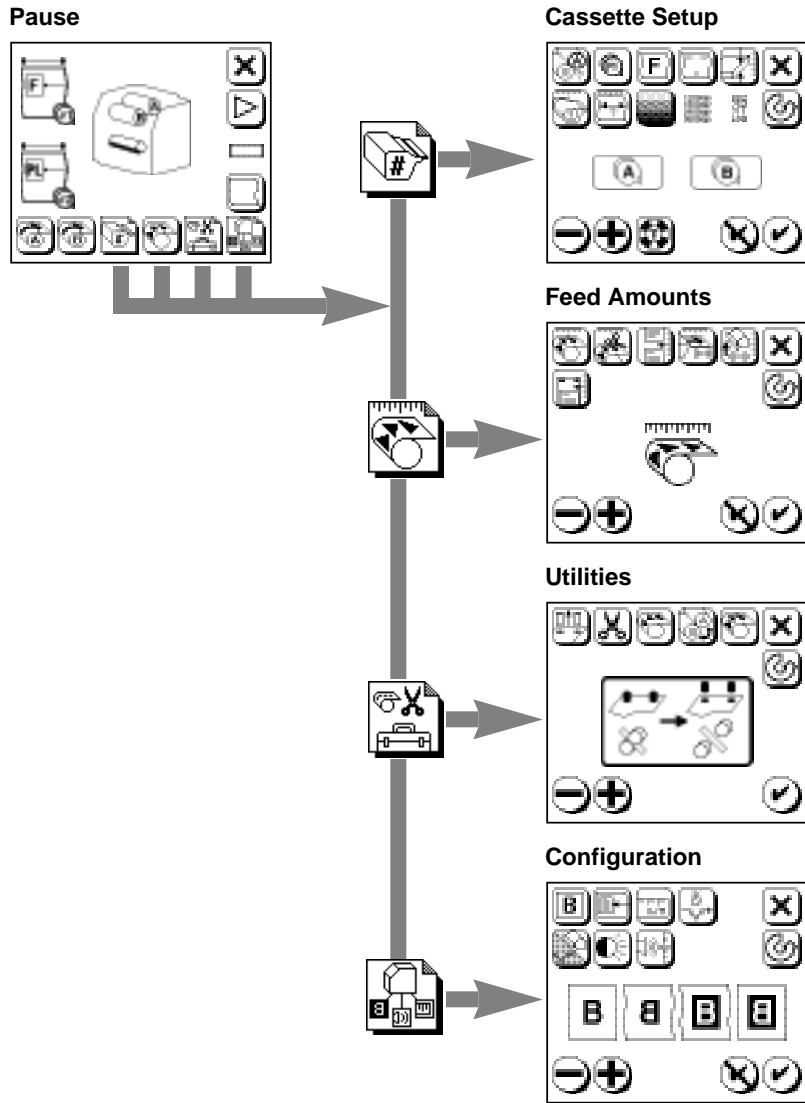









Figure 2.3. Press the square cornered buttons in the Pause Screen to access the other control panel screens.

Basic Controls

These buttons are the basic controls in the control panel screens:

- ①  **Abort:** Appears in all screens. In the Run Screen, Abort cancels a job that is being imaged. In the Pause Screen, Abort cancels feed or cut functions. In other screens, Abort cancels the current operation and returns you to the Pause Screen.
- ②  **Pause:** Puts the imagesetter in pause and returns to the Pause Screen. In pause, you can change parameters or perform tasks such as loading media.
- ③  **Run:** Puts the imagesetter in run mode, ready to image jobs, and returns to the Run Screen.
- ④  **Minus:** Decreases the value of numerical parameters. Toggles between selections when icons show choices.
- ⑤  **Plus:** Increases the value of numerical parameters. Toggles between selections, as in Minus.
- ⑥  **Cancel:** Discards any changes in the current screen.
- ⑦  **Accept:** Accepts the parameters that appear on the screen.

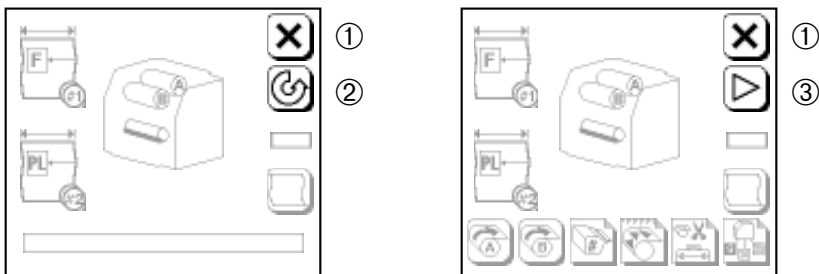

Figure 2.4. Left: Run Screen. ① Abort; ② Pause.
Right: Pause Screen. ① Abort; ③ Run.

Special Features of **Plus** and **Minus**

- **Interchangeable**
Press either Plus or Minus to make selections.
- **Cycling through selections**
The different selections for a function act as if they are on a loop. When you reach the end of the possible selections or numerical values, the list begins again.
- **Auto-repeat function**
If you press and hold down either Plus or Minus, the signal is automatically repeated. This enables you to make large changes quickly. This is useful when making large changes to numerical values such as exposure settings or media amounts.

Special Features of **Accept** and **Cancel**

- In the Cassette Setup, Feed Amounts, and Configuration screens, Accept and Cancel appear after you press Plus or Minus to change a parameter.
- In the Utility screen, Cancel does not appear.

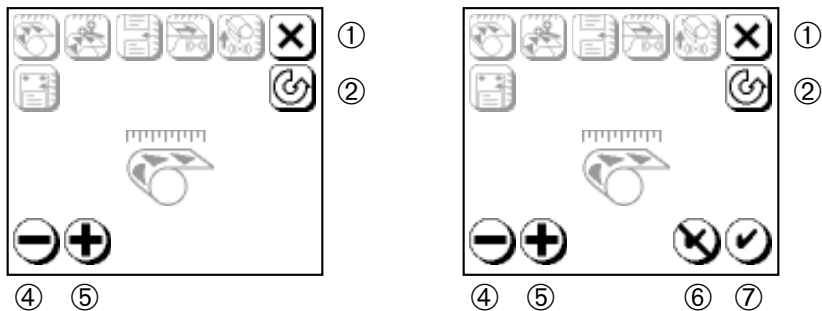

Figure 2.5. The Feed Amounts Screen. Left, before you change a parameter.
Right, after you press either Plus (5) or Minus (4) to change a parameter,
Accept (7) and Cancel (6) appear.

Using Functions

To use a function, you need to go to the control panel screen that contains that function.

Select a Screen

- Press Pause to go to the Pause Screen.
- Press a button to select the screen you need to use.

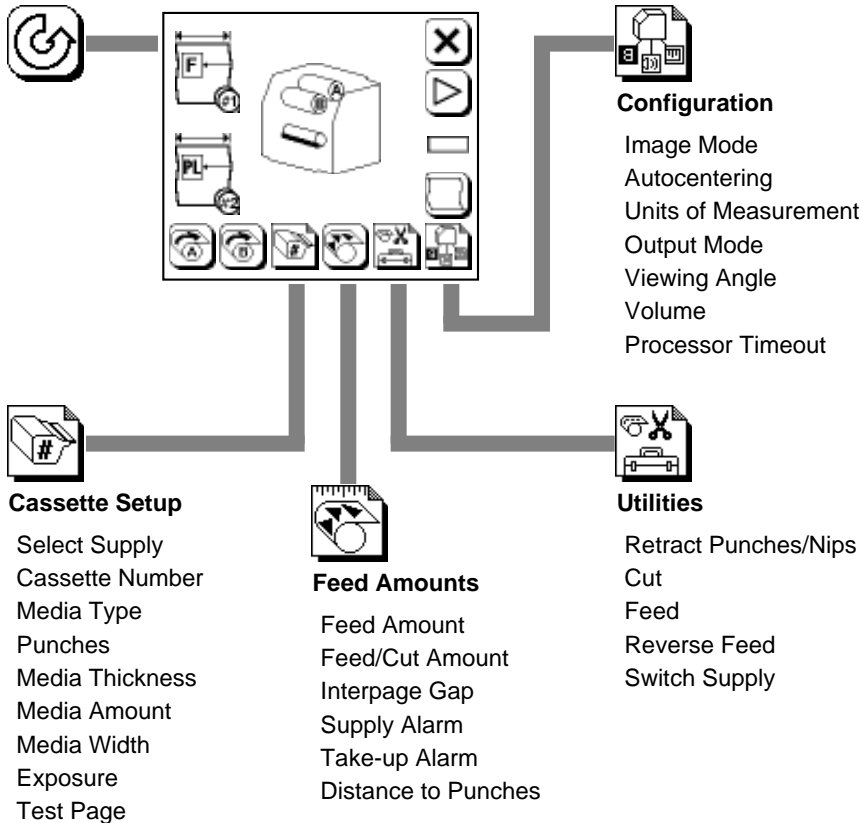

To Set a Parameter

- Press the icon that represents the parameter you need to change.
- Select the desired setting. Use Plus or Minus.
- Confirm your selection. Press Accept to keep or Cancel to discard changes.

In some cases, you select from limited choices. This example shows how to set the imaging mode in the Configuration Screen.

1. Press Pause, Configuration, Select Image Mode.

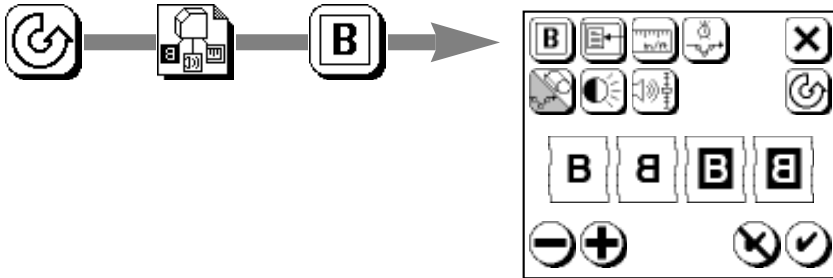

2. Select the image mode:

 Press Plus or Minus to select image mode.

Choices (left to right):

 Right reading positive
Wrong reading positive
Right reading negative
Wrong reading negative.

3. Accept or Cancel:

 Press Accept to change the image mode, or...

 ...press Cancel to discard.

To Specify a Numerical Value

In other cases, you specify a number. This example shows how to change the media amount in the Cassette Setup Screen.

1. Press Pause, Cassette Setup, Media Amount.

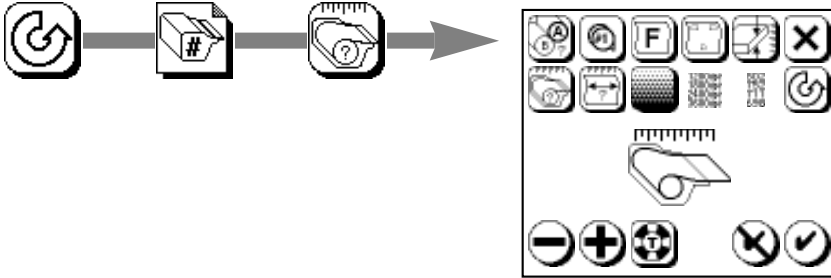

2. Change the media amount setting:



Press Plus or Minus to change the media amount.

Range:



0.0 to 250.0 feet
0.0 to 76.2 meters

3. Accept or Cancel:



Press Accept to change the media width, or...



...press Cancel to discard.

Press Some Buttons Twice

To activate some functions, you need to press a button twice. For example:

To Load a Supply:



Press once and the icon flashes.



Press again to complete loading or...



...press Abort to cancel.

In all cases, the button flashes when a second press is required. If you do not press the button a second time within five seconds, the function cancels itself.

Buttons Display Current Setting

For some functions, the button icon changes to show the current setting for that function. When you change the parameter, the button changes. Figure 2.6 shows an example.

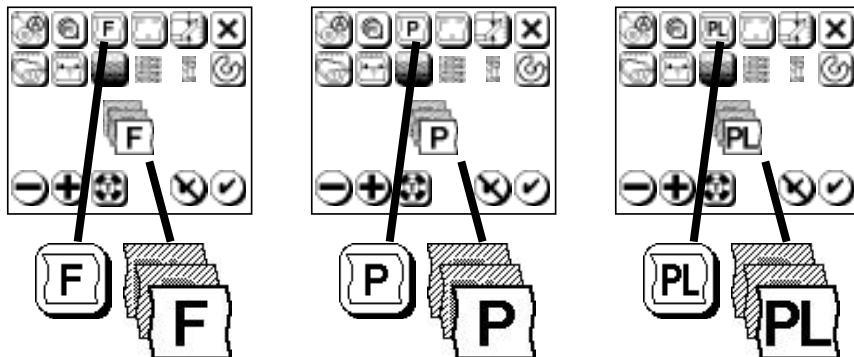

Figure 2.6. As you select different types of media in the Cassette Screen, the Media Type button changes .

Left, film selected; center, paper selected; right, plate selected.

Chapter 3:
Using the Control Panel

Introduction

This chapter describes the functions and features of the six control panel screens. It provides the information you need for the daily operation of the SelectSet Avantra imagesetter.

The following topics are described:

- The Run Screen
- The Pause Screen
- Status Icons that appear in the Run and Pause Screens
- The Cassette Setup Screen
- The Feed Amounts Screen
- The Utilities Screen
- The Configuration Screen

Many of the functions you perform at the SelectSet Avantra control panel can also be performed by downloading RIP user tools to your RIP. Certain features of the SelectSet Avantra can be activated only by RIP user tools.

For more information, see *Appendix C: RIP User Tools* in this user guide and refer to your RIP documentation.

The Run Screen

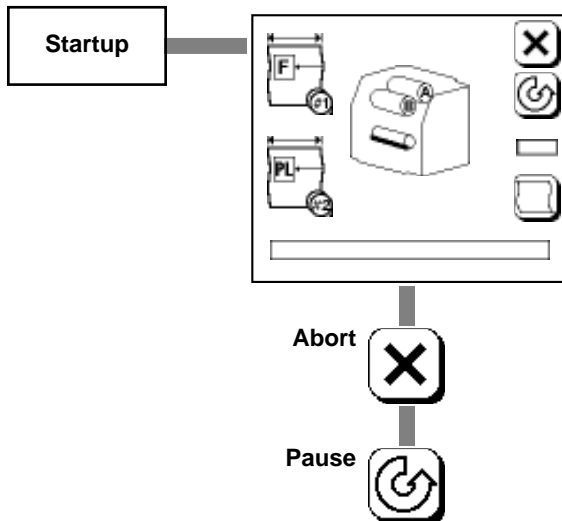

Operating Modes

The SelectSet Avantra has three operating modes in the Run Screen:

- **Idle:** Ready to image a job
- **Busy:** Imaging a job
- **Pause Pending:** The imagesetter will go into Pause when the job currently imaging is complete

Progress Bar

- The progress bar appears at the bottom of the Run Screen.
- While the imagesetter is busy, the outline of the progress bar appears in bold. The bar fills in to indicate the progress of the job.

Current Job Information

- The name of the job being imaged appears over the progress bar. This information is cleared when the job is finished.
- A limited number of spaces are available to display the name. Job names that are too long are cut from the left.
- The page, copy, and separation appear above the job name.

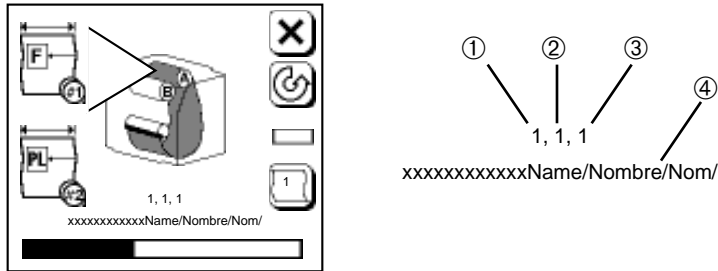
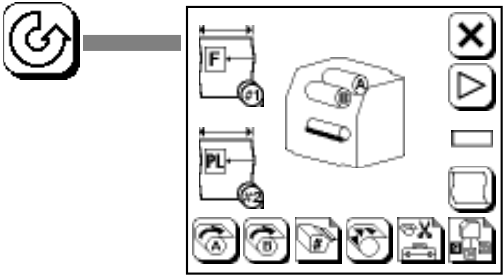



Figure 3.1. ①—Page number. Corresponds to page number that appears when you display job history. ②—Copy (if you are imaging multiple copies of a job.)
③—Separation number. ④—Job name.

Pause Pending

- Press Pause in the Run Screen while the imagesetter is busy to enter Pause Pending.
- The Pause button blinks to indicate Pause Pending.
- To cancel Pause Pending, press Pause a second time. The blinking stops.
- When the current job is finished, the Pause Screen appears. You can perform media operations, check parameters, etc.
- Press Run to resume imaging. If jobs were left in queue when the imagesetter went into Pause, the imagesetter continues where it left off.

The Pause Screen



Load Supply A

Load Supply B
(Available only with DualSupply Option.)

Cassette Setup

Feed Amounts

Utilities

Configuration

Display Job History

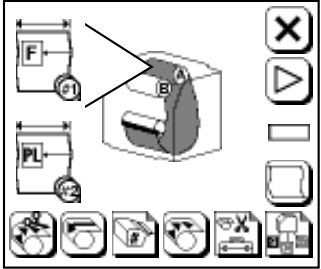
Feed and Cut

Unload

Load a Media Supply

When you press Load, the imagesetter advances media from a supply cassette into the drum.

To Load a Supply:



Press once and the icon flashes.



Press again to complete loading or...



...press Abort to cancel.

Feed and Cut

Press Feed and Cut to advance media out of the drum.

To Feed and Cut:



Press once and the icon flashes.



Press again to complete the feed and cut or...



...press Abort to cancel.

The Output Mode that you specify in the Configuration Screen affects the Feed and Cut function. Your choices for Output Mode are Take-up Cassette or On-line Processor.

When you use the on-line processor:

- Imaged media is fed past the cutter.
- The media is cut. The imagesetter ignores the Feed Cut Amount.
- The imagesetter feeds the cut media through the bridge to the processor.

When you use the take-up cassette:

- Imaged media is fed past the cutter.
- Some unexposed media is advanced. The length of the unexposed media is the Feed Cut Amount, specified in the Feed Amounts Screen.
- The media is cut.

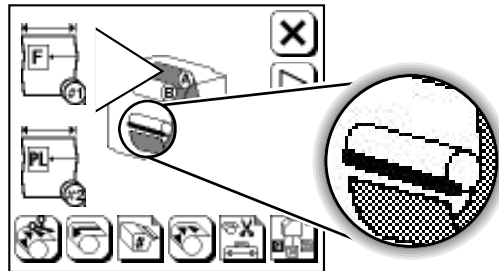

Figure 3.2. The display changes to show that the media has been cut.

Unload

When you press Unload, the imagesetter:

1. Checks for media in the take-up cassette or imaged media in the drum.
2. Executes a feed and cut if media is detected in either place.
3. Rewinds the media in the drum back into the supply cassette.

To Unload:



Press once and the icon flashes.



Press again to complete unloading or...



...press Abort to cancel.

Display Job History

When you press Display Job History, the imagesetter displays the names of the last five jobs that have been imaged.

1. Press Pause, then Display Job History.

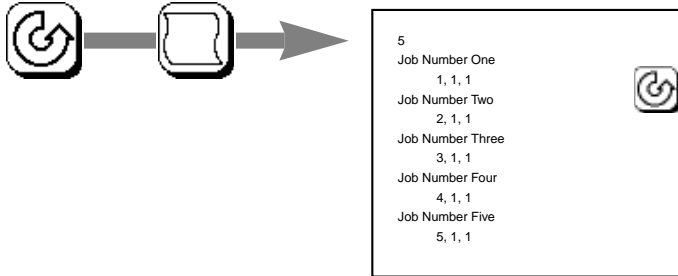

2. Press Pause to return to the Pause Screen.



- The first line shows the number of jobs currently in the display.
- Subsequent lines show the job name, then this information; page, copy, separation. This is shown in the same format used in the Run Screen.
- This function only displays jobs that are completed. Jobs that you abort at the imagesetter control panel do not appear.
- A limited number of spaces are available to display the name. Job names that are too long are cut from the left.
- New job names are added to the bottom of this list.
- The oldest entry is discarded when the list exceeds five jobs.
- This list is cleared when you shut down or reset the imagesetter.

Run and Pause Status Icons

This section describes status icons that appear in the Run Screen and the Pause Screen.

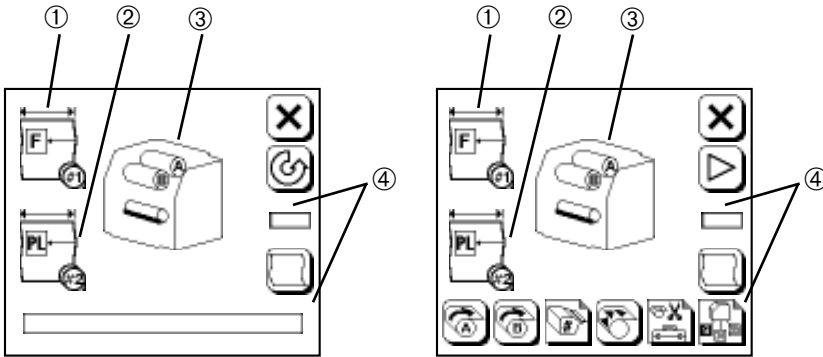

Figure 3.3. The Run Screen (left) and the Pause Screen (right).

- ① —Media status, supply A.
- ② —Media status, supply B (appears only with DualSupply Option).
- ③ —Engine status. ④ —Job status.

Media Status

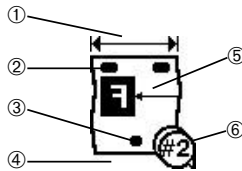

Figure 3.4. The media status display.

- ①—Media width. ②—Top punch. ③—Bottom punch. ④—Media remaining.
- ⑤—Media type, alignment mode, imaging mode. ⑥—Cassette number.

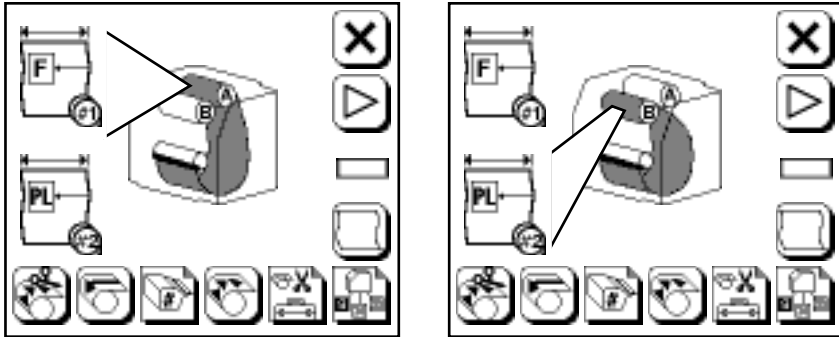

Figure 3.5. The display changes to show that a media supply is loaded.
 Left, DualSupply A loaded. Right, DualSupply B loaded.

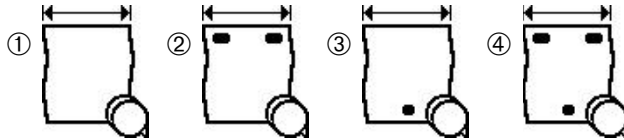

Figure 3.6. Punch modes. Adjust in Cassette Screen.
 These symbols are used as a convention to represent the many different punch configurations that are available.

- ①—Punches off. ②—Top punches on. ③—Bottom punches on.
- ④—Top and bottom punches on.

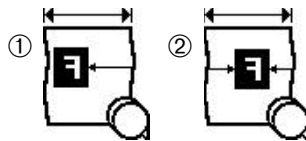

Figure 3.7. Alignment mode. Adjust in Configuration Screen.
 ①—Flush left. ②—Centered.

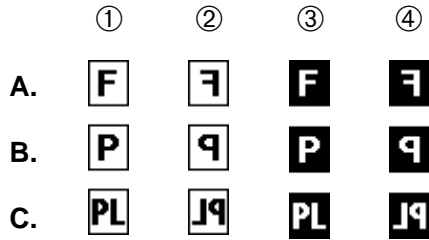

Figure 3.8. The four Imaging modes are listed left to right.
 You change imaging mode in the Configuration Screen.
 ①—Positive right reading. ②—Positive wrong reading.
 ③—Negative right reading. ④—Negative wrong reading.
 The three media types are listed top to bottom.
 You change media type in the Cassette Screen.
 A—Film. B—Paper. C—Plate.

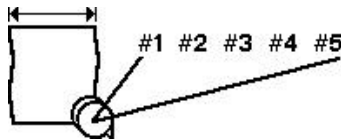

Figure 3.9. Cassette number. Adjust in Cassette Screen.

Engine Status

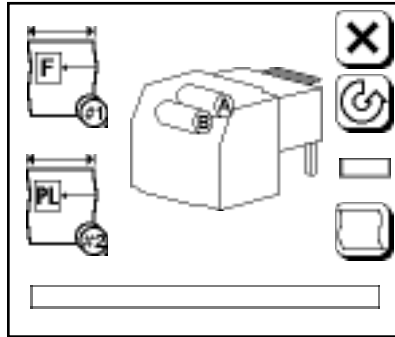

Figure 3.10. Engine status changes when you specify an on line processor in the Configuration screen.

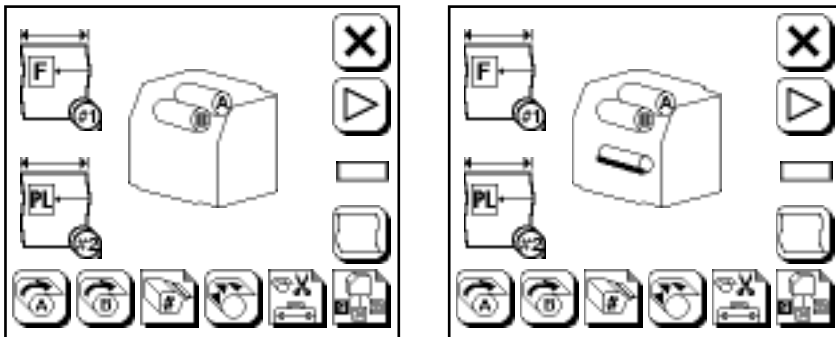

Figure 3.11. Left, take-up cassette out. Right, take-up cassette in.

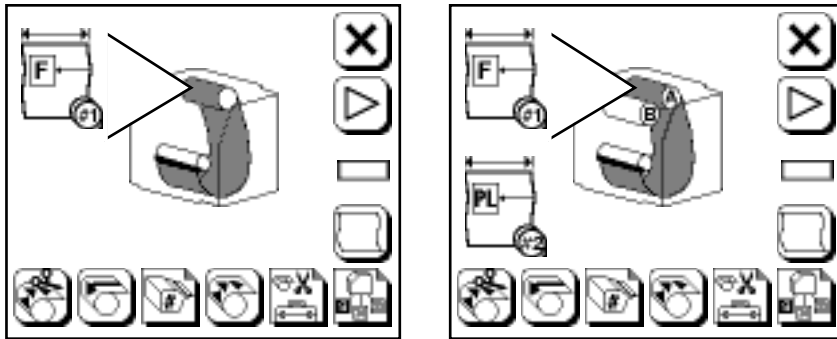

Figure 3.12. Media loaded. Left, single media supply. Right, DualSupply.

Job Status

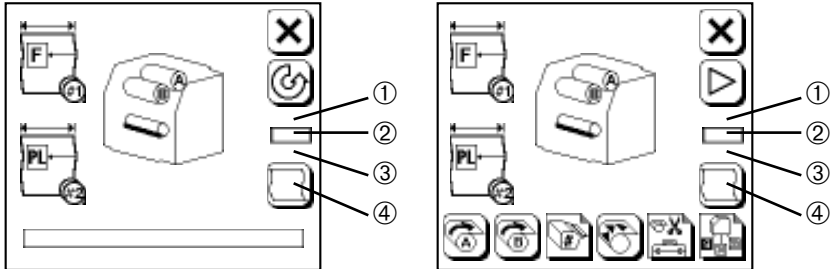

Figure 3.15. Job status display. Run Screen (left) and Pause Screen (right). ① —Current resolution. ② —Current exposure.
③ —Media past the cutter. ④ —Job counter.

Current Resolution: The current resolution being used by the imagesetter is displayed.

- The imagesetter changes resolution based on commands embedded in the file that is being imaged or commands downloaded to the RIP from the front end.

Current Exposure: The current exposure value is displayed.

- When the imagesetter changes resolution, it automatically uses the exposure specified in the Cassette Setup Screen for that resolution.

Media Past the Cutter: The imagesetter displays the amount of media that has been advanced past the cutter.

Job Counter: The number inside the Display Job History button is the number of images in the drum and take-up cassette.

- If the imagesetter is busy, this number includes the job being imaged.
- The counter advances every time a job is started, even if you abort the job before it is complete.

Supply Alarm

- You specify the Supply Alarm amount in the Feed Amounts Screen.
- When the media remaining amount in the current loaded supply drops below this amount, an alarm appears.
- The alarm blinks until you reload media.
- The imagesetter continues imaging until the supply cassette is completely empty. At this point, error message 4, Out of Media, appears on the control panel.

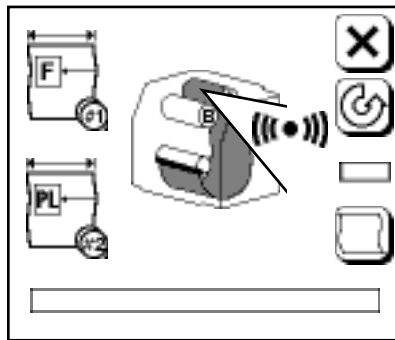

*Figure 3.13. Supply alarm.
Appears in both the Run and Pause screens.*

Take-up Alarm

- You specify the Take-up Alarm amount in the Feed Amounts Screen.
- When the media fed into the take-up cassette exceeds this amount, an alarm appears.
- The alarm blinks and the imagesetter goes into Pause Pending; it will go to Pause when the current job is finished.
- When the Pause Screen appears, feed and cut the media, remove the full take-up cassette, and put an empty cassette in its place.
- To override the alarm, press Run. The imagesetter goes to the Run Screen and begins the next job; it will again go into Pause Pending and Pause at the end of this job.
- You can also increase the Take-up Alarm amount. When the imagesetter is in the Pause screen, press Feed Amounts, change the alarm amount and continue imaging.

Note: The maximum limit for the take-up cassette is 100 feet (30.4 m). Exceeding this limit can scratch the media or jam the cassette.

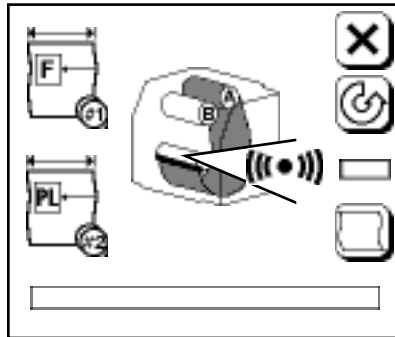
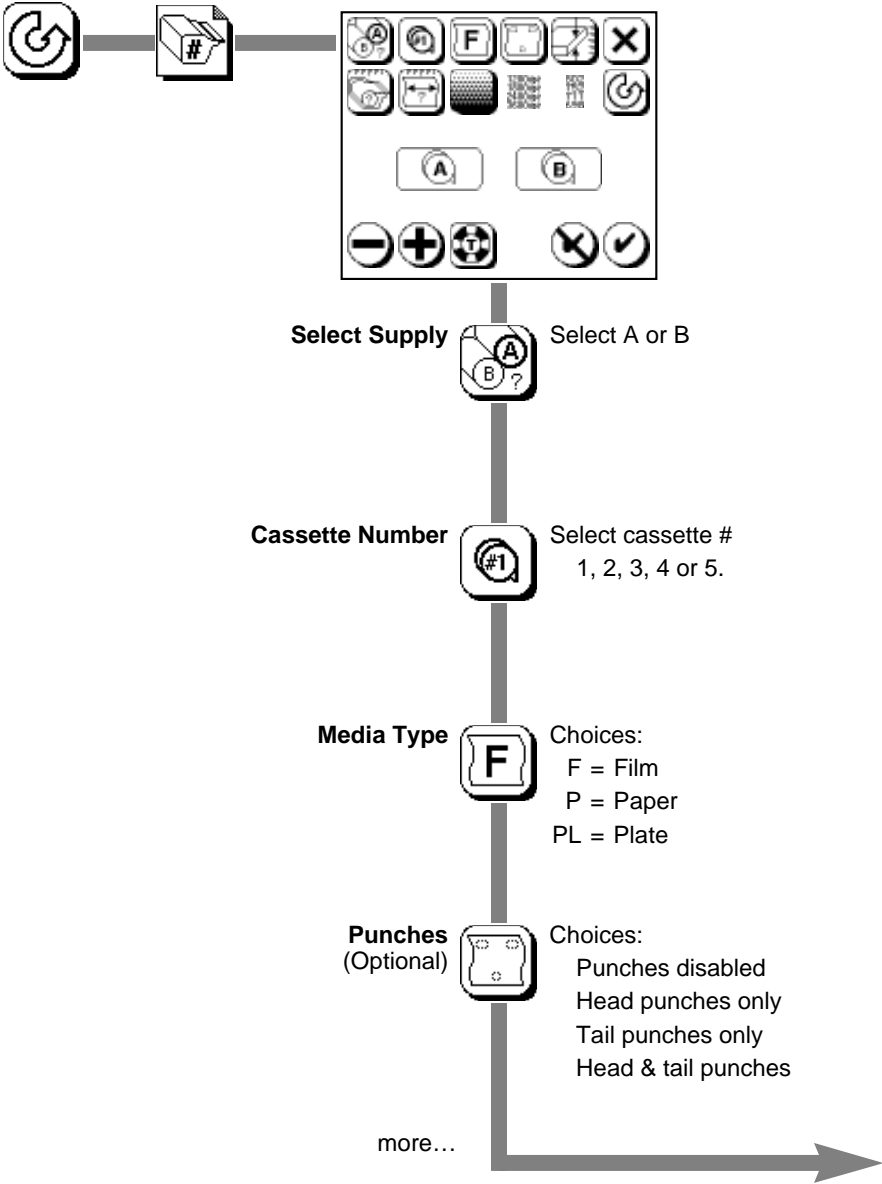

Figure 3.14. Take-up alarm.
Appears in both the Run and Pause screens.

The Cassette Setup Screen

Press Pause, then Cassette Setup



Cassette Setup, continued...

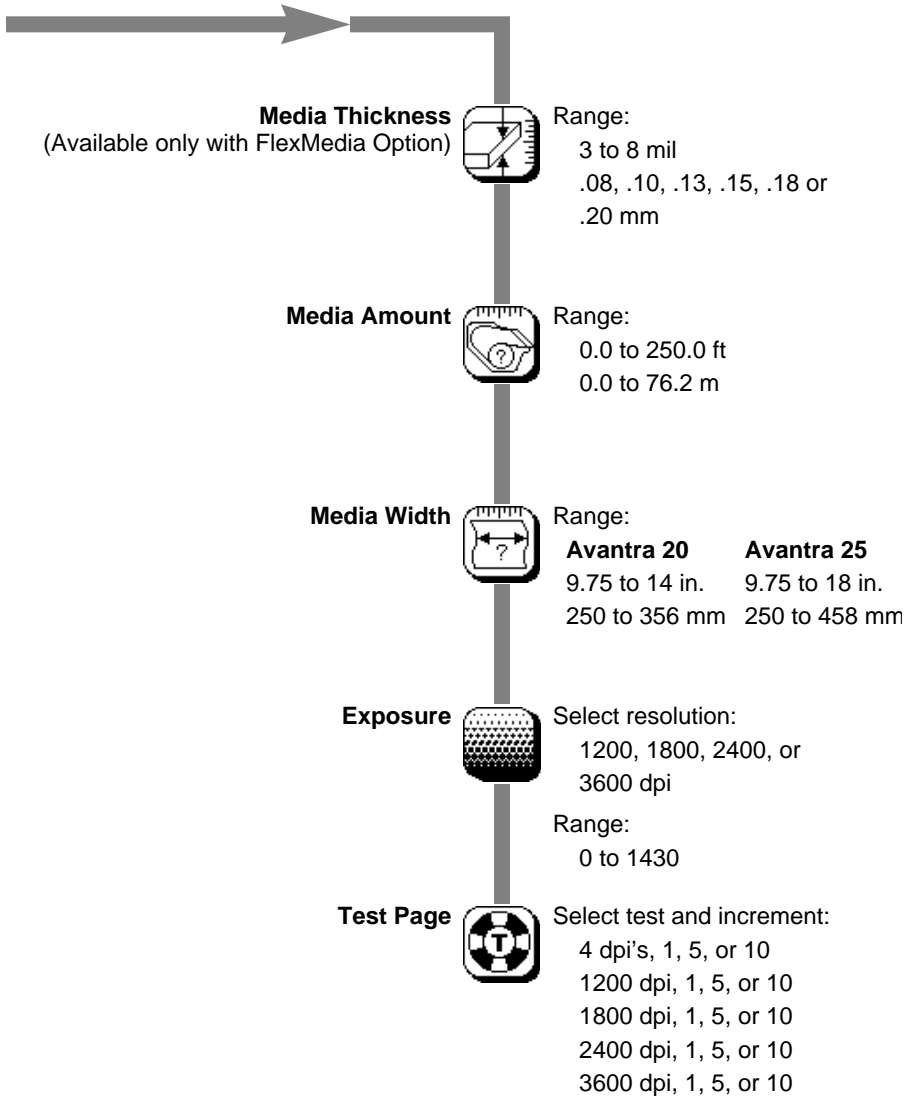

Exposure Settings

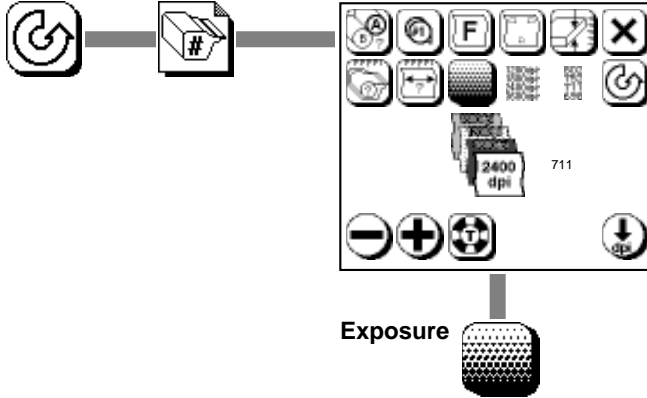

1. Select resolution:

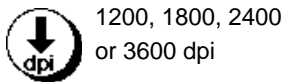

2. Adjust exposure:



3. Accept or cancel:



4. Repeat as needed:

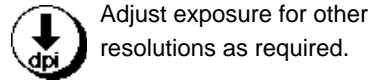

Run exposure tests to determine the optimum exposure setting for your work. Run tests for each media type and each imaging resolution before you begin production.

See *Chapter 5: Exposure Tests* for information about running and evaluating test pages. See *Appendix A: Image Quality* for more information about exposure settings.

Cassette Parameters

You can define up to five different sets of cassette parameters. If you define and use cassette parameters, you can change a group of parameters on the SelectSet Avantra just by selecting a different cassette number.

Consider this example:

A shop uses film in three different widths. Operators frequently need to change among them. Cassette 1 is loaded with 12 inch (305 mm), cassette 2 is loaded with 14 inch (355 mm), and cassette 3 is loaded with 18 inch (458 mm) film. When changing supply cassettes, the operator changes the cassette number at the control panel. The imagesetter reads the stored parameters from memory.

Consider these advantages:

- Save time by not having to key in a new set of parameters.
- Reduce the chances of operator error.
- Easy tracking of media remaining in a cassette.

Note: DualSupply cassettes and media punches are extra-cost options. If an option is not installed, the icon that governs the feature is grayed out.

Specifying a Cassette Number

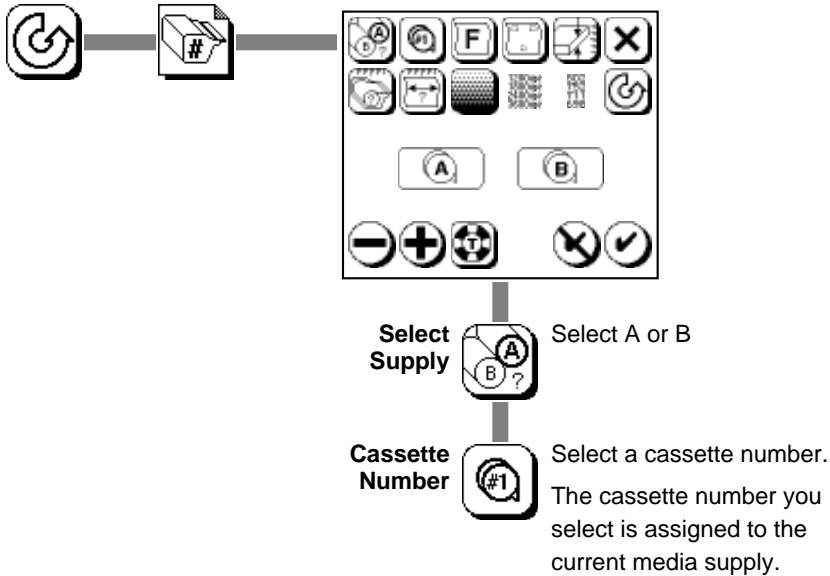

After you select a cassette number, all parameters you change affect that cassette.

You can change or examine parameters for a cassette that is not currently installed in the imagesetter.

On imagesetters with the optional DualSupply cassettes, you cannot assign the same cassette number to both supplies. For example:

- Cassette 1 is specified as Supply A.
- You select Supply B.
- You can specify cassettes 2, 3, 4 or 5 for Supply B.
- You cannot specify cassette 1 for Supply B.

List of Cassette Parameters

This table lists the different cassette parameters and provides space for recording the settings you use. Make a copy of this form to keep in your work area.

Cassette Number	1	2	3	4	5
Media Type	_____	_____	_____	_____	_____
Punches	_____	_____	_____	_____	_____
Media Thickness	_____	_____	_____	_____	_____
Media Width	_____	_____	_____	_____	_____
Exposure 1200 dpi	_____	_____	_____	_____	_____
Exposure 1800 dpi	_____	_____	_____	_____	_____
Exposure 2400 dpi	_____	_____	_____	_____	_____
Exposure 3600 dpi	_____	_____	_____	_____	_____

You can also record information directly on the supply cassette. There is a blank white space on the back of the cassette where you can write with an erasable marker. For example, you might choose to record the media remaining amount in this space.

The Feed Amounts Screen

Press Pause, then Feed Amounts.

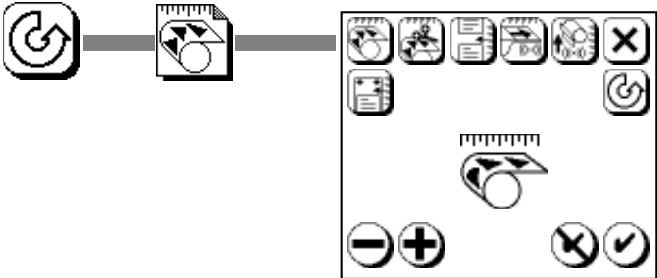

Feed Amount  Range:
0.0 to 39.0 in
0 to 99 cm

Feed Cut Amount  Range:
0.0 to 39.0 in
0 to 99 cm

Interpage Gap  Range:
0.0 to 10.0 in
0 to 25.4 cm

more...



Feed Amounts, continued...

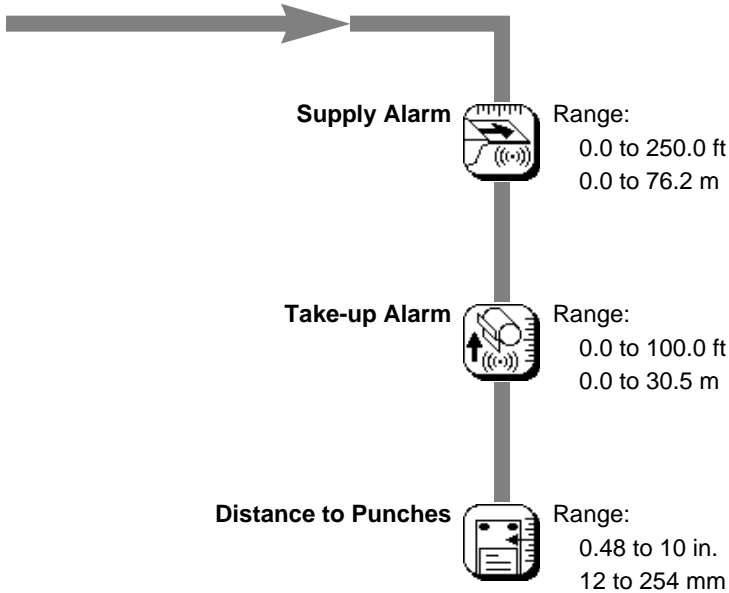

Definitions

Feed Amount: Media fed when you use Feed in the Utilities Screen or when you send a feed command from your front end.

Feed and Cut Amount: Media fed between most recent job and a cut. Used by Feed and Cut in the Pause Screen.

Interpage Spacing: Media fed between jobs.

Supply Alarm Amount: When the amount of media remaining in a supply cassette is less than this amount, an alarm appears.

Take-up Alarm Amount: When the amount of media fed into the take-up cassette is greater than this amount, an alarm appears.

Distance to Punches: Distance from the center of the top punches to the leading edge of the image.

The Utilities Screen

Press Pause, then Utilities.

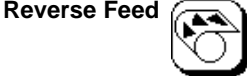
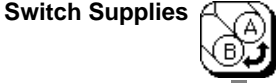
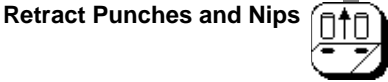
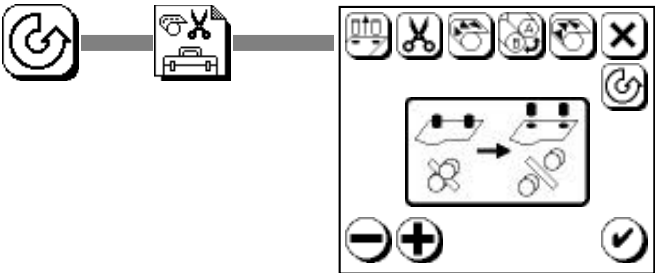

To Use Utilities Functions

1. Select a function.



For example, press cut.

2. Press Accept.



Press once and the icon flashes.



Press again to confirm or...



...press Abort to cancel.

Definitions

Retract Punches and Nips: Rollers called *nip rollers* and punches hold media in place. Press Retract Punches and Nips to release media. Use when clearing jams.

Cut: Cuts media with no media feed. Before the imagesetter makes the cut, it checks to make sure that at least 6" (15.3 cm) has been fed past the cutter. This prevents you from cutting a short piece of media that could slip between the feed rollers and cause a jam.

Feed: Feeds the amount of media specified by Feed Amount in the Feed Amounts Screen.

Reverse Feed: Use to unload media when a media jam or carriage jam prevents you from using Unload in the Pause Screen. Rewinds media into the supply cassette without making a Feed and Cut and without centering the media shields in the drum. If there is media in the take-up cassette, press Cut before Reverse Feed.

Switch Supplies: On imagesetters with the DualSupply option, use when supply rollers are not set to the correct position for the supply that you want to load or remove.

The Configuration Screen

Press Pause, then Configuration.

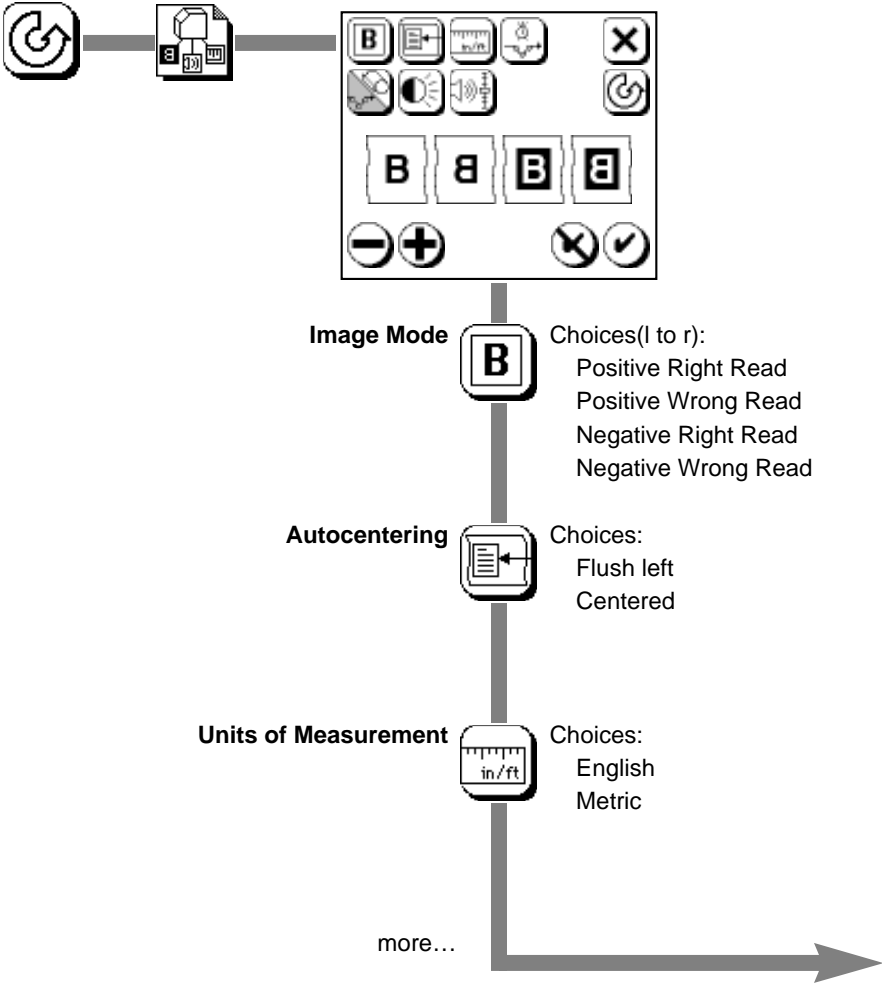

Configuration, continued...

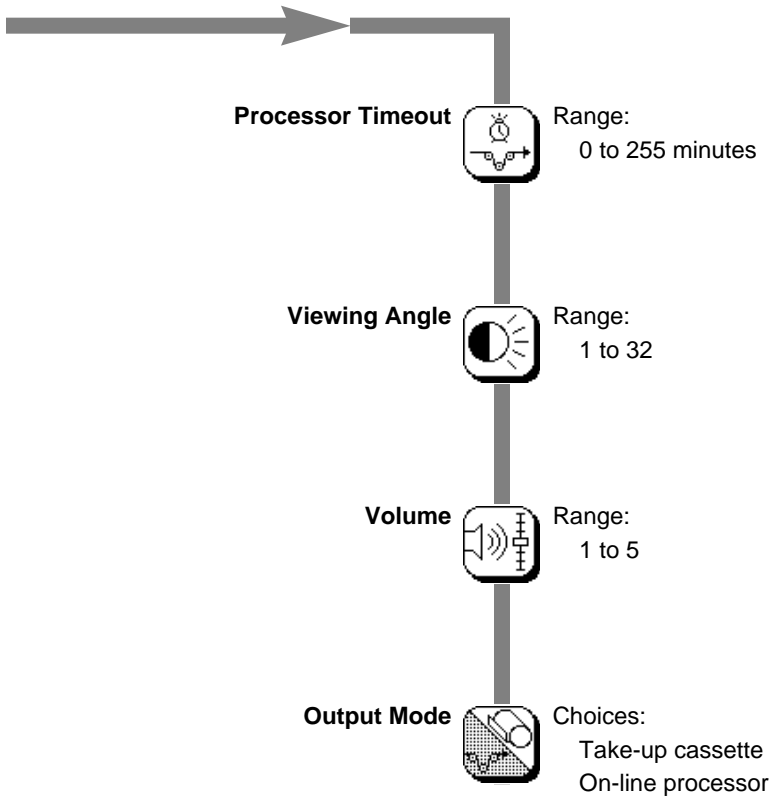

Definitions

Processor Timeout: For use with on-line processor. Sets time delay after last job. When the delay period ends with no activity at the im-agesetter, the last job is advanced, cut, and fed to the processor. Set this value to 0 to shut it off.

Viewing Angle: Changes the contrast of the control panel screen for better viewing. Optimum setting is a matter of personal preference.

Volume: Changes the loudness of the control panel speaker.

Image Mode

- **Positive Right Reading:**
Type and images exposed; background unexposed.
Right reading with the media emulsion side up.
- **Positive Wrong Reading:**
Type and images exposed; background unexposed.
Right reading with the media emulsion side down.
- **Negative Right Reading:**
Type and images unexposed; background exposed.
Right reading with the media emulsion side up.
- **Negative Wrong Reading:**
Type and images unexposed; background exposed.
Right reading with the media emulsion side down.

Chapter 4:
Media Operations

Introduction

This section describes:

- Loading media into supply cassettes.
- Installing loaded supply cassettes into the imagesetter.
- Removing supply cassettes from the imagesetter.
- Using take-up cassettes: Loading them into the imagesetter, removing them from the imagesetter.

Loading Media into Supply Cassettes

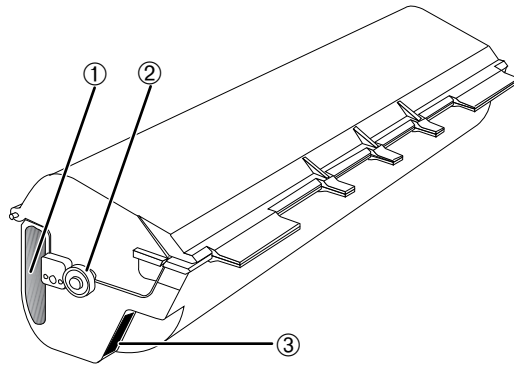

Figure 4.1. The supply cassette. ①— Handle. ②— Bearing. ③— Gear opening.

Step 1. Remove the media roll from the cassette.

Place the supply cassette on a level surface.

Open the cassette and remove the empty media roll.

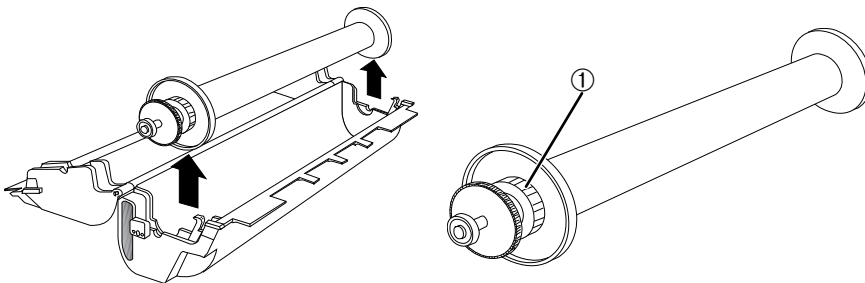

Figure 4.2. Remove the empty media roll. Loosen the outer locking knob ①.

Remove the endcaps from both ends of the roll. Loosen the outer locking knob, then tap the bearing with the palm of your hand.



Figure 4.3. Remove the endcaps.

Step 2. Adjust the endcaps to match the media width.

Loosen the small locking knob. If necessary, use the special wrench supplied with the imagesetter to loosen the knob.

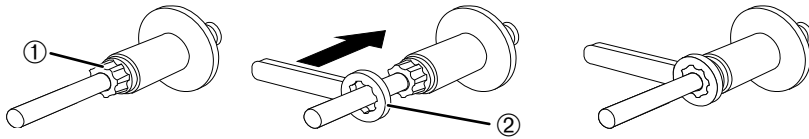

Figure 4.4. Loosen the small locking knob ①. Use the wrench ② if necessary.

Slide the shaft to adjust. It will click into place. Markings indicate the correct position for various media widths.

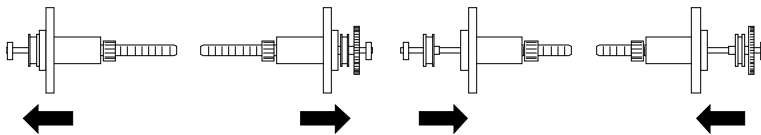

Figure 4.5. Adjust the position of the shaft.

Hold the endcap by the outer locking knob and tighten the small locking knob.

Note: If you are reloading the supply cassette with the same width media, check to make sure that the endcaps are still set correctly.

Step 3. Attach the end caps to the media roll.

Hold the new roll of media so that the flap of the light-proof wrapper is on top of the roll, pointed away from you.

Insert the endcap with no gear into the left end of the media roll.

Insert the endcap with the gear into the right end of the media roll.

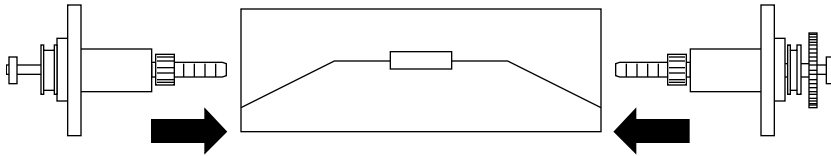

Figure 4.6. Attach the endcaps to the new roll of media.

Tighten the outer locking knob to secure each end cap.

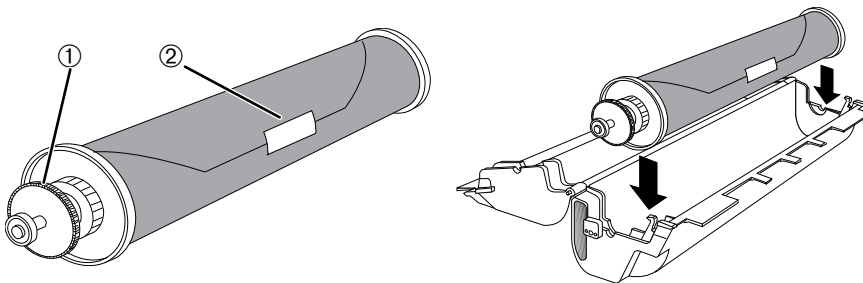

Figure 4.7. Left, note the orientation of the gear ① and the wrapper ②. Right, place the media in the cassette.

Step 4. Place the media roll in the cassette.

Put the new media roll into the cassette.

Make sure that the end cap with the gear goes to the right.

Use your thumb to smooth paper against and over both end-caps.

Step 5. Open the media wrapper and close the cassette.

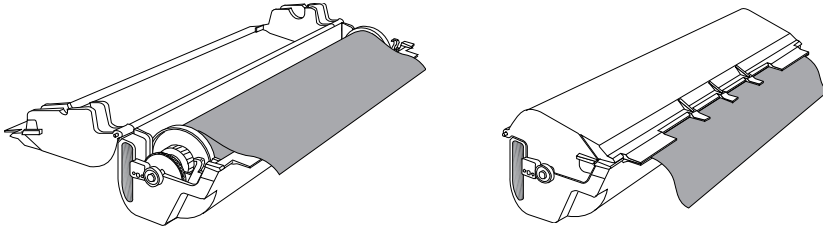

Figure 4.8. Close the cassette and pull the media wrapper out of the cassette.

Remove the tape that secures the media wrapper. Pull the wrapper so that it hangs over the edge of the supply cassette.

Close the cassette, then slowly pull the wrapper out of the cassette until you see the media.

Note: Pull the wrapper out of the cassette gently and slowly. The media roll turns freely and you could pull too much media out of the cassette.

Remove the wrapper and adjust the media so that it extends approximately $\frac{1}{4}$ " (6 mm) beyond the supply cassette fingers. See Figure 4.9.

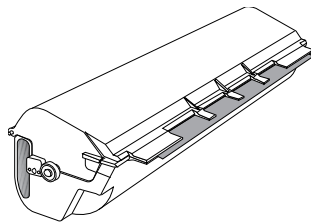

Figure 4.9. The media extends approximately $\frac{1}{4}$ " (6 mm) beyond the supply cassette fingers.

Installing Loaded Supply Cassettes

Note: If your imagesetter is not equipped with the DualSupply Option, status icons and button icons that deal with Supply B are grayed out.

Step 1. Put the cassette into the imagesetter.

Open the imagesetter top cover and the light shield.

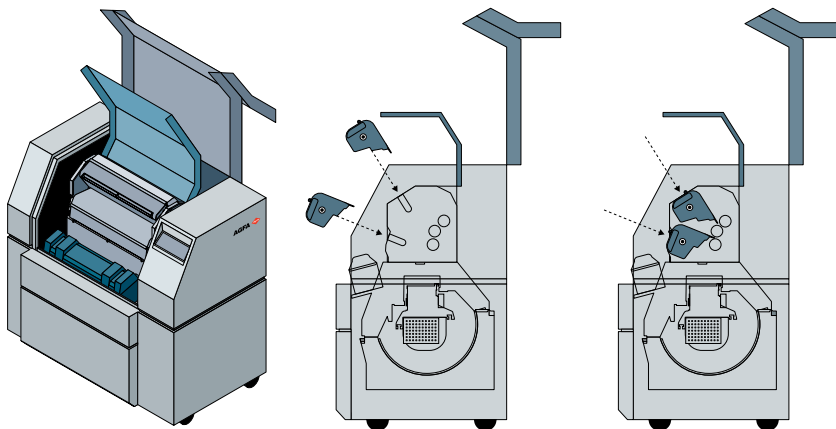

Figure 4.10. Left, top cover and light shield open.
Center and right, sliding the supply cassette into the imagesetter

Slide the supply cassette into the imagesetter.

The bearings that extend out the end of the cassette fit into slots in the side of the media compartment.

If media is hanging beyond the fingers of the supply cassette, make sure that it fits between the open rollers without bending or folding.

On systems with the DualSupply Option, make sure that the rollers are open to receive media from the supply cassette you are inserting. If not, use Switch Supplies in the Utilities Screen.

Close the light shield and top cover.

Step 2. Update the cassette parameters.

Press Pause, then Cassette Setup.

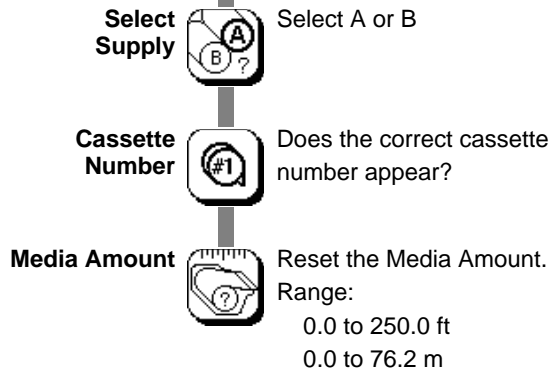
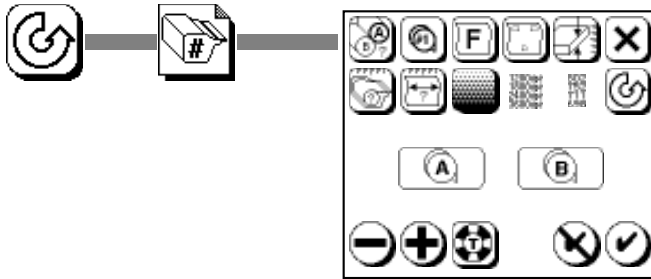

Make sure that the correct cassette number is assigned to the supply cassette.

If the cassette is loaded with a new roll of media, reset the media remaining amount.

Check the other parameters.

If you are loading a new kind of media, run exposure tests.

Step 3. Press Load to feed media from the supply into the imager drum.

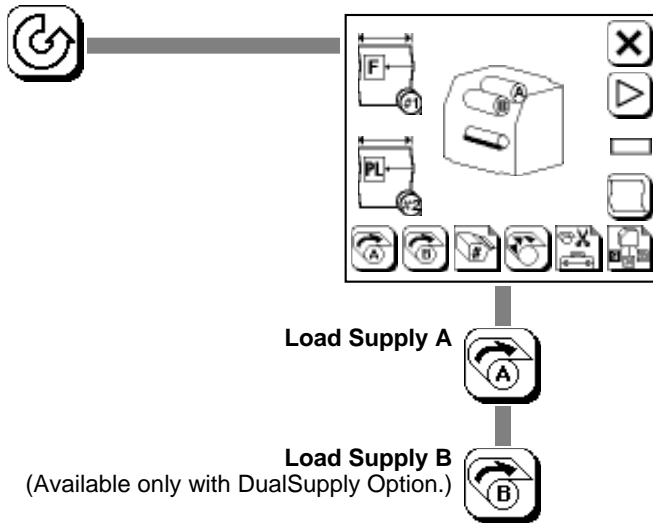

To Load a Supply:



Press once and the icon flashes.



Press again to complete loading or...



...press Abort to cancel.

Removing Supply Cassettes

Step 1. Unload the media supply.

If there is media in the take-up cassette, the imagesetter automatically does a feed and cut when you unload a media supply. In this case, you need to remove the take-up cassette before you can load another supply cassette.

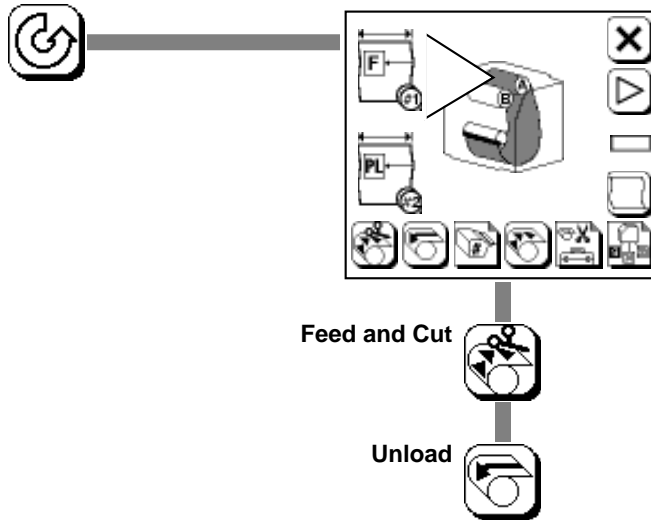

To Feed and Cut:

 Press once and the icon flashes.

 Press again to complete the feed and cut or...

 ...press Abort to cancel.

To Unload:

 Press once and the icon flashes.

 Press again to complete unloading or...

 ...press Abort to cancel.

Step 2. Remove the Cassette

Open the imager top cover and the light shield.

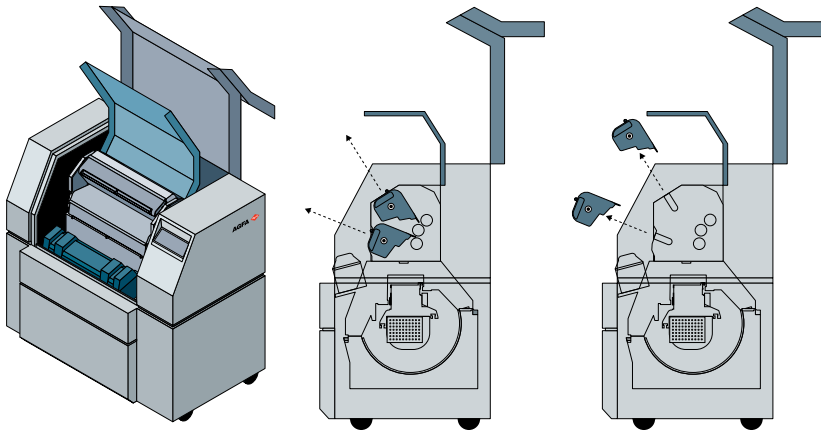

Figure 4.11. Left, top cover and light shield open.
Center and right, sliding the supply cassette out of the imager

Pull the cassette gently but firmly out of the imager.

Use the handles built into the cassette. Keep the cassette straight as you pull it out.

If you are removing a cassette that still contains media, about one inch (2.5 cm) of media will protrude past the opening of the cassette. You can rewind this back into the cassette or trim it off.

To rewind the media, turn the gear that appears at one end of the supply cassette.

Caution:

Do not rewind the media all the way into the cassette. If you rewind the media too far, you need to open the cassette in a darkroom to pull the end out. Opening the cassette in normal room light will expose a large quantity of the media in the cassette.

Take-up Cassettes

The take-up cassette is motor driven. This feature makes it possible for the cassette to receive up to 100 feet (30 m) of exposed media.

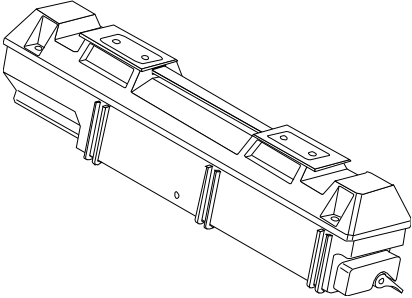

Figure 4.12. The take-up cassette.

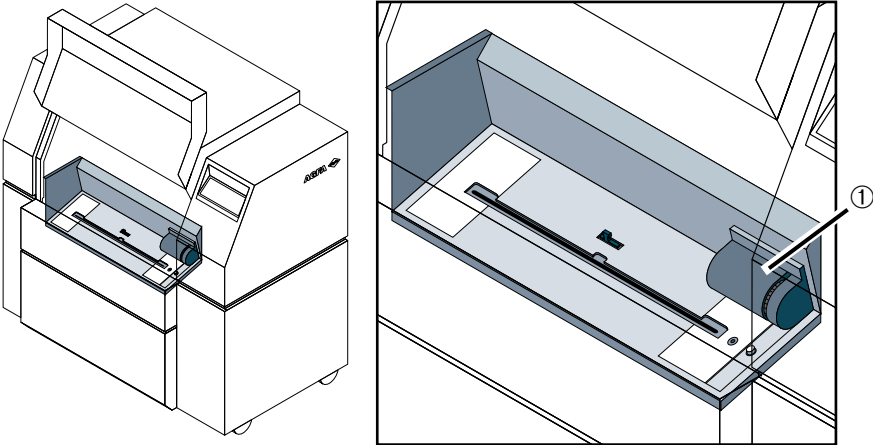

Figure 4.13. The take-up cassette area. Note the location of the drive motor ①.

Removing Take-up Cassettes

1. Open the lower front cover.
2. Grab the take-up cassette by the handle at the top.
3. Tilt the cassette toward you and lift it out of the media compartment.

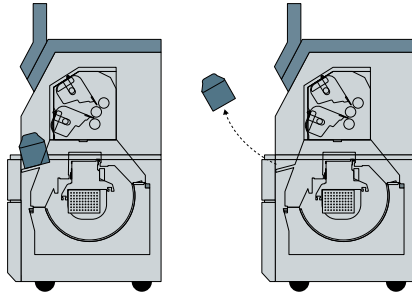

Figure 4.14. Removing the take-up cassette.

Inserting Take-up Cassettes

1. Open the lower front cover.
2. Hold the take-up cassette so that, as you face the imagesetter, the latch that opens and closes the media slot is on the left.
3. Line up the cassette with the cassette sensor and the take-up drive wheel and press it down into position. Make sure that the cassette is securely in place.
3. Close the lower front cover.

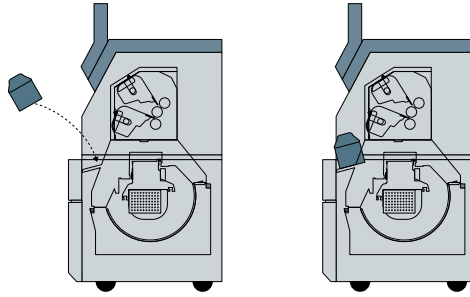

Figure 4.15. Inserting the take-up cassette.

Opening and Closing the Media Slot

The opening in the take-up cassette is called the media slot. A lever at the end of the cassette opens and closes this slot.

- To open the slot, press the lever in and turn it counter-clockwise.
- Open the slot before you put it into a processor. This allows the media to move freely out of the cassette.
- To close the slot, press the lever in. This releases a spring that closes the slot.
- Close the slot when you put the cassette into the imagesetter.

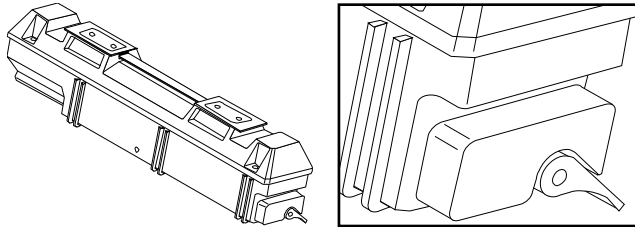

Figure 4.16. The lever at the end of the take-up cassette opens and closes the media slot in the bottom of the cassette.

Chapter 5:
Exposure Tests

Introduction

This chapter describes how to run exposure tests and how to evaluate these tests to determine optimum exposure settings for the SelectSet Avantra.

The following topics are covered:

- A description of the test page
- Running exposure tests
- Evaluating exposure tests

The Test Page

Exposure test pages are created by files that are part of the SelectSet Avantra software. Use test pages to evaluate exposure settings.

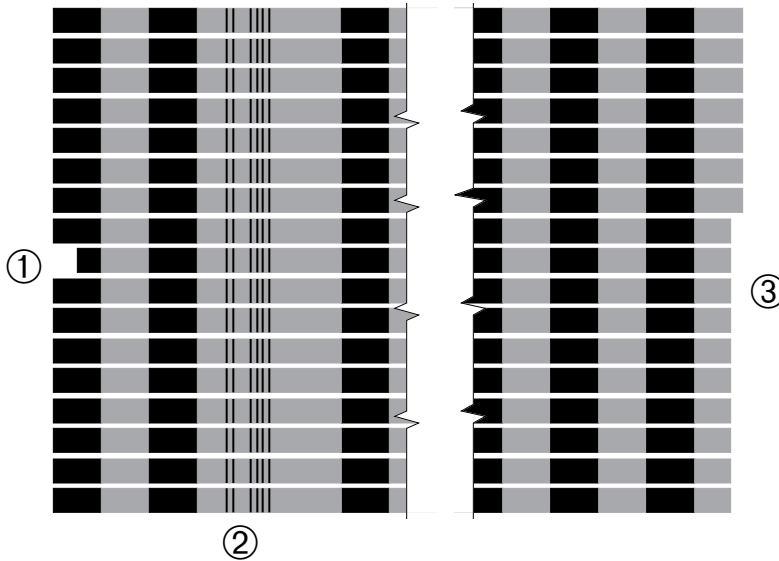

Figure 5.1. An example of a test page.

- ①—Reference band, indicated by an indent at the left side of the test page.
- ②—Imaging resolution, indicated by a bar code.
- ③—Increment value, indicated by indents at the right side of the test page.

- A test page is made up of a number of bands imaged at different exposures.
- The bands consist of black 100% regions and gray 50% regions.
- The number of bands on the page varies with the width of the media.
- A *reference band* near the center of the page is imaged at the current exposure set in the Cassette Screen. The reference band is indented at the left end of the test page. See ① in Figure 5.1.

- The resolution is indicated by a bar code. See Figure 5.2.

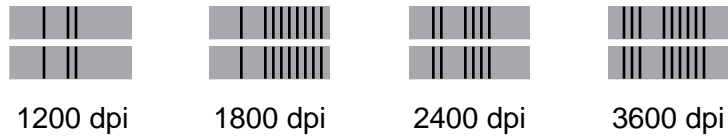

Figure 5.2. Bar codes indicate the resolution (dpi value) used to image a test page.

- The increment, or difference in the exposure setting from one band to the next, is indicated by indents at the right end of the test page. See Figure 5.3.

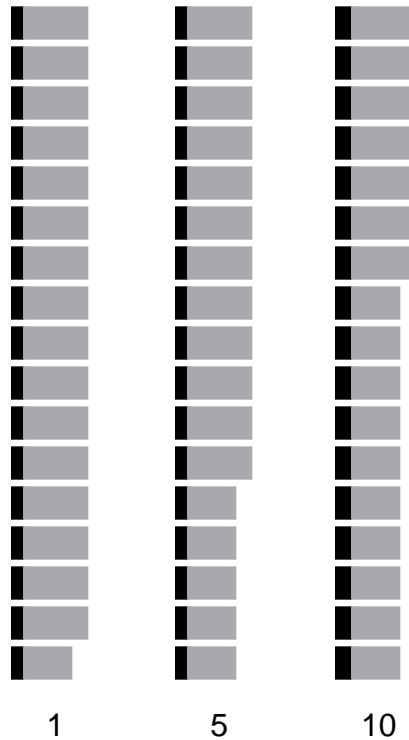

Figure 5.3. Indents show the increment value, expressed in exposure units.

The 4 DPI's Test Page

The 4 dpi's test page is made up of four smaller test images.

- Each image uses a different resolution.
- The reference band for each image is exposed at the current setting for that resolution.
- All four images use the same increment value.

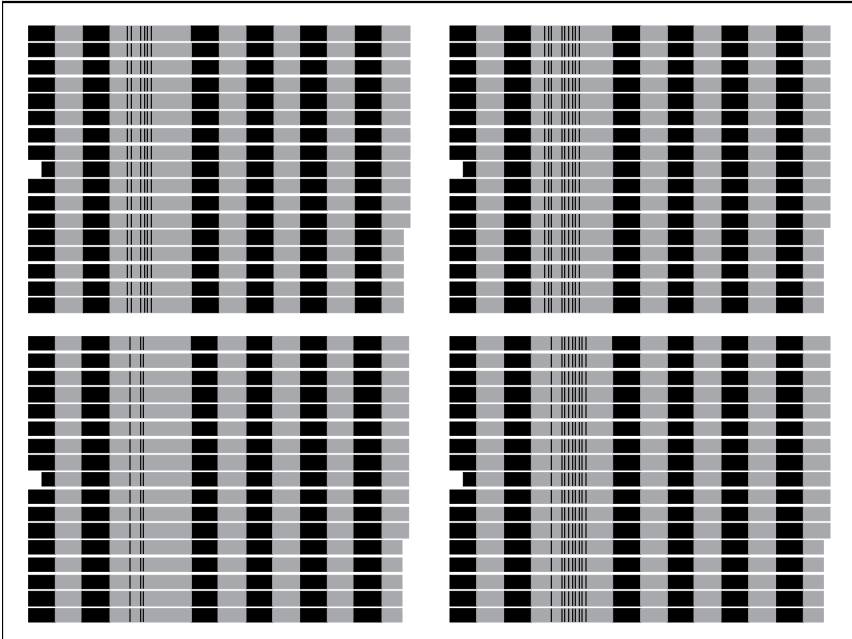

Figure 5.4. The 4 dpi's test page.

Running Exposure Tests

Before you begin production, execute and evaluate exposure tests to determine the optimum exposure setting for each resolution. To maintain high quality standards, repeat this procedure at regular intervals.

These are the basic steps of the procedure:

1. Execute a test page from the control panel.
2. Process the medium.
3. Evaluate your results.
4. Set the exposure value.

When to Image a Test Page

Image a test page:

- When you first use a new imaging medium. (For example, when you first change from film to plate.)
- When you change emulsion batches. (The product label attached to each case and each roll of Agfa photographic media is stamped with a number that identifies the emulsion batch.)
- When you load a new roll of media or when you replace the chemicals in your media processor.
- When you change processing conditions (new processor, different type of chemistry, and so on).
- At some regular interval (daily or every other day) to ensure quality control.

Note: Run separate exposure tests for each resolution setting. The optimum exposure value varies for each one.

How to Image an Exposure Test Page

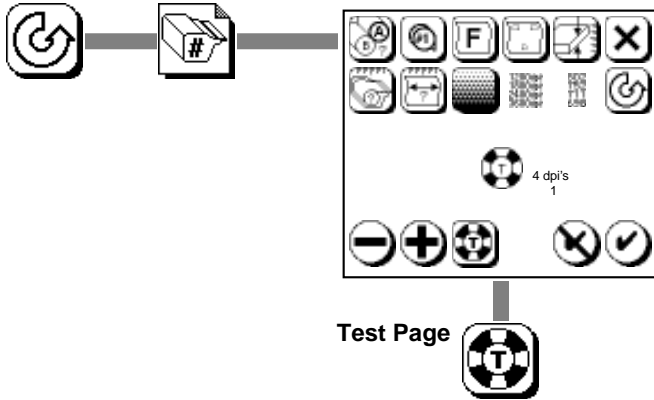

1. Select a test page:



Select test:

4 dpi's, 1, 5, or 10
1200 dpi, 1, 5, or 10
1800 dpi, 1, 5, or 10
2400 dpi, 1, 5, or 10
3600 dpi, 1, 5, or 10

2. Image the page:



Press Accept to begin the test page or...



...press Abort to cancel.

When selecting an increment value, follow these guidelines:

- An increment value of 10 is useful when you are not sure what the exposure setting should be. (When evaluating a new type of media, for example.) The higher value yields the widest range of exposures on the test image.
- Use the lower values (5 or 1) when you have a better idea what the exposure setting should be.
- In tests run with higher increment values, the lowest and highest exposures may be far out of range. In this case, determine which exposure setting is closest to the results you need, set that as the exposure, then run the test again using a smaller increment value.
- Expect each resolution to have a unique optimum exposure.

When you image a test page, the imagesetter advances the exposed media out of the drum.

While the test page is being imaged, a progress bar appears in the Cassette Screen.

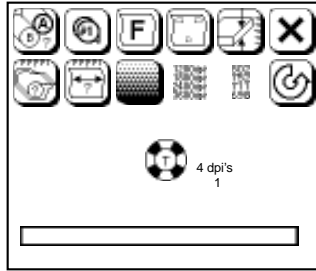

Note: When you use an on-line processor, the SelectSet Avantra automatically advances, cuts, and feeds an imaged test page to the processor.

Reading a Test Page

To read the exposure values for each band on a test page, hold the page with the reference band indent to the left and the increment value indents to the right. See Figure 5.5.

The imagesetter follows this pattern to select exposure settings for each band on the test page:

Higher exposures toward the top of the page...

Step +3 (current exposure) + (3 x increment value)

Step +2 (current exposure) + (2 x increment value)

Step +1 (current exposure) + (1 x increment value)

Reference band (current exposure)

Step -1 (current exposure) - (1 x increment value)

Step -2 (current exposure) - (2 x increment value)

Step -3 (current exposure) - (3 x increment value)

Lower exposures toward the bottom of the page...

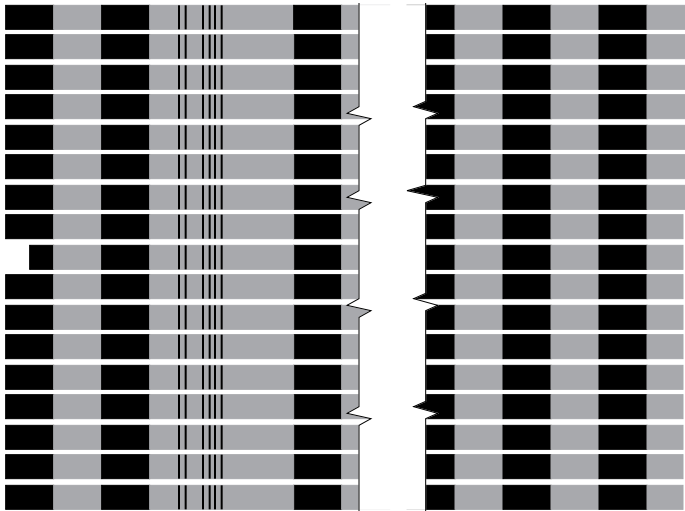

Figure 5.5. To read a test page, hold it like this.

For example, if the current exposure setting is 592 and the increment value is 10:

Higher exposures...

$$\text{Step +3 } (592) + (3 \times 10) = 592 + 30 = 622$$

$$\text{Step +2 } (592) + (2 \times 10) = 592 + 20 = 612$$

$$\text{Step +1 } (592) + (1 \times 10) = 592 + 10 = 602$$

Reference band (592)

$$\text{Step -1 } (592) - (1 \times 10) = 592 - 10 = 582$$

$$\text{Step -2 } (592) - (2 \times 10) = 592 - 20 = 572$$

$$\text{Step -3 } (592) - (3 \times 10) = 592 - 30 = 562$$

Lower exposures...

Evaluating Test Pages

After you process the exposure test page, evaluate it. Use a densitometer to determine which test exposure is the best for your purposes.

Densitometers

There are two types of densitometers.

- **Transmission Densitometer**
Measures how much light passes through processed film. Use for evaluating film.
- **Reflection Densitometer**
Measures how much light is reflected by an opaque image. Use for evaluating photographic paper, plate material, or press print.

Make sure that you know how to use your densitometer before you begin the evaluation procedure.

Set the Exposure

After you evaluate a test page and determine the optimum exposure for each combination of media and resolution, you need to set the exposure values. This procedure is described in *Chapter 3: Using the Control Panel*.

Chapter 6:
Diagnostics and
Error Messages

Introduction

This chapter contains:

- Information about error messages.
- Procedures for clearing error messages from the control panel.
- Procedures for using the internal modem for error reporting.
- Procedures for bypassing boot errors.

Error Procedures

When an error occurs, media, job, and engine status icons are replaced with an error icon. For example, the control panel looks like this when reporting error 5, No Take-up Cassette:

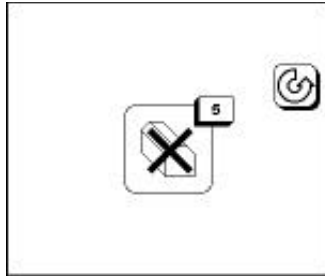

Clearing Errors

Step 1: Identify the error message, then press Pause.

Step 2: Correct the problem and continue.

Resetting

To correct some errors, you need to reset the system.

Step 1: Turn the imagesetter off and let it remain idle for a few minutes.

Step 2: Restart the imagesetter. You may also need to reboot the RIP before you can continue.

Error Messages

This section lists the error codes and describes corrective action.



1 Carriage Jam

Motion of the carriage has been blocked.

Reset the imagesetter and retry the original operation. If the error returns immediately, the carriage may be getting caught on media in the drum. See the section *Unload Media Using the Utility Screen* in this chapter.



3 Cutter Jam

The power cutter is jammed.

Retry the cut operation. If the error persists, call for service.



4 Out of Media

The supply cassette is empty.

Load media into the supply cassette.

You may find up to 12" (30.5 cm) of media extending out of the take-up cassette when you remove it after an Out of Media error message.



5 No Take-up Cassette

The take-up cassette is not in place or is not seated correctly.

Put in the take-up cassette. If the cassette is in the media compartment, make sure that it is seated correctly.



6 Media Jam

Go to the Utilities Screen; press Feed, then Accept. If this does not clear the error, see the section *Unload Media Using the Utility Screen* in this chapter.

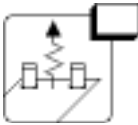

7 Output Side Punch Jam

Retry the operation. If the error persists, call for service.



8 Cutter in Media Path

Go to the Utilities Screen; press Cut, then Accept.

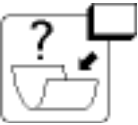

11 Carriage Hit End of Travel

Reset. Retry the operation. If the error persists, call for service.



12 Hardware Error

Reset. If the error persists, call for service.



13 Left Side Door Open

The left door is not securely closed.

Close the door. When you clear the message, the image-setter resets itself.



14 RIP Data Error

The RIP sent more data than it specified.

Reset. Process the job that generated the error. Make sure that it is complete. If the error persists, call for service.



15 No RIP

Check to see if your RIP is running. Check cable connections between RIP and imagesetter.

Reset. If the error persists, call for service.



17 Spinner Speed Error

Hardware error.

Reset. If the error persists, call for service.



22 Spot Aperture Jam

The device that adjusts the laser spot size is jammed.

Reset. If the error persists, call for service.



23 Boot Diagnostic Error

Hardware error detected while attempting to boot.

Reset. If the error persists, call for service.

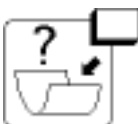

25 Carriage Switch Broken

Hardware error.

Reset. If the error persists, call for service.



27 Processor Alarm Signal

The optional on-line media processor is reporting an alarm. This message appears as an overlay on the screen that is currently displayed on the imagesetter control panel.

The imagesetter will finish the current job, but will not image another job or advance media until you correct the error at the processor.

Check the alarm signal LEDs on the processor control panel. For more information, see the section *Alarm Signals* in chapter 9.

After you correct the error at the processor, the imagesetter automatically resumes operation.



28 Hardware Error

Reset. If the error persists, call for service.

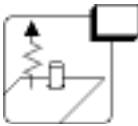

31 Input Side Punch Jam

Reset and retry the command. If the error persists, call for service.

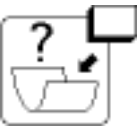

32 Carriage Position Error

The system detected a problem with the carriage while imaging.

Reset. If the error persists, call for service.

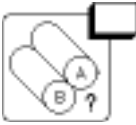

33 No Media Currently Loaded

Go to the Pause Screen and load a media supply.



34 Media in Take-up Cassette

There is cut media in the take-up cassette. Remove the cassette. Put an empty cassette in the imagesetter in its place.



36 Supply Cassette Jam

Check to make sure that the supply cassette is positioned correctly. If necessary, unload and load the supply again. If the error persists, call for service.

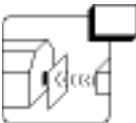

37 Take-up Cassette Jam

Make sure that the take-up cassette is positioned correctly and that nothing is blocking the end of the cassette from the sensor.



38 Focuser Jam

Hardware error.

Reset. Call for service if the error persists.



39 Polarizer Error

Hardware error.

Reset. Call for service if the error persists.



40 Diagnostic Error

Hardware error.

Reset. Call for service if the error persists.



41 Bridge not in Position

Open the media compartment and make sure that the bridge to the processor is completely lowered.

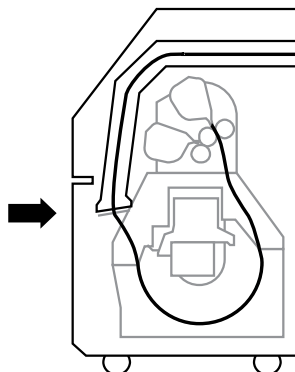

Figure 6.1. Make sure that the bridge is completely lowered.



42 Right Side Door Open

The right door is not securely closed.

Close the door. When you clear the message, the image-setter resets itself.



43 Internal Error

Reset. Call for service if the error persists.



44 Cut Not Allowed

Not enough media has been fed past the cutter.

If this message appears when you use Cut in the Utilities Screen, clear the message, press Feed, then press Cut again.



45 Feed and Cut Before Changing Supply

A media supply is already loaded and media from that supply has been imaged and advanced into the take-up cassette.

Feed and cut the media and remove the take-up cassette. Unload the current supply, then load the other supply.



46 Laser Bad

Hardware error.

Reset. Call for service if the error persists.



47 Carriage Speed Error

Motion of the carriage has been blocked.

Open the side panel to find the problem.



48 Invalid Engine Configuration

Hardware error.

Reset. If the error persists, call for service.



49 Hardware Error

Reset. If the error persists, call for service.



50 Hardware Error

Reset. If the error persists, call for service.



51 Bridge Communication Error

An error occurred in communication between the image-setter and the bridge.

Reset. If the error persists, call for service.



52 Bridge Jam Before Center Sensor

Open the media compartment and remove the top and bottom bridge covers.

Look for media in the lower section of the bridge. If you find no media in the bridge, lift the bridge up and look for media protruding from the media slot. See Figures 6.2 and 6.3.



53 Bridge Jam At Processor Entry

Open the media compartment and remove the top bridge cover.

Look for media caught near the entry to the media processor. See Figures 6.2 and 6.3.



54 Bridge Jam After Center Sensor

Open the media compartment and remove the top bridge cover.

Look for media caught on the top section of the bridge. See Figures 6.2 and 6.3.



55 Bridge Motor Jammed

Open the media compartment and remove the top and bottom bridge covers.

Media could be caught anywhere on the bridge. See Figures 6.2 and 6.3.



56 No Response, Bridge Entry Sensor

Open the media compartment and lift the bridge up out of the way.

Look for media protruding from the media slot. See Figures 6.2 and 6.3.

If you find no media, remove the nip drive assembly. (This procedure is described in the section *Clearing Media Jams* in chapter 7.)

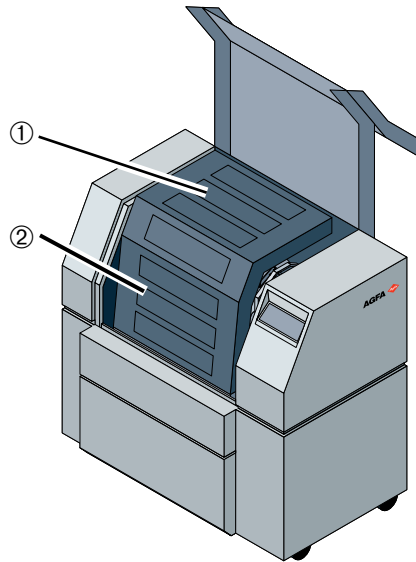

Figure 6.2. Bridge for the on-line processor. ①—Top cover. ②—Bottom cover.

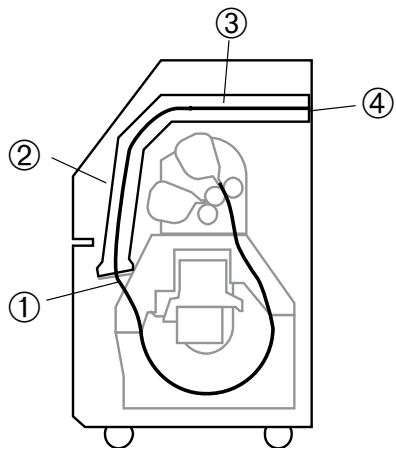

Figure 6.3. Locations on the bridge media path.
①—Media slot. ②—Lower section.
③—Top section. ④—Entrance to media processor.



57 Processor Error

The on-line processor is reporting an Input Jam, an Exit Jam, or a Motor Overload error.

Clear the error and check the on-line processor control panel. For more information, see the section *Processor Status and Error Messages* in chapter 9.

The imagesetter will abort the current job, and will not image another job or advance media until the processor error is cleared.



58 No Processor Communication

The on-line processor is not communicating with the imagesetter.

Check the processor to make sure that it is on.



59 Processor Top Door Open

The top door in the on-line processor is open. This door needs to be open when you use the processor off-line. If this message appears and you are not currently using the processor off-line, check to make sure that the door is securely closed.

The imagesetter will finish the current job, but will not image another job or advance media until the door is closed. After you close the door, the imagesetter automatically resumes operation.



60 Processor Communication Error

There has been an error in the flow of messages between the processor and the imagesetter.

Reset the processor.

Errors 100 and Above

Error messages numbered 100 and above are reported by diagnostic software that the imagesetter runs as it boots up. For more information, see the section *Boot Errors* in this chapter.

Special Error Procedures

This section contains detailed procedures for clearing errors.

Unload Media Using the Utility Screen

Follow this procedure to unload media using the functions in the Utilities Screen.

- Go to the Utilities Screen.
- If there is media in the take-up cassette, press Cut then Accept to cut it.
- Rewind media back into the supply cassette. Press Reverse Feed then Accept.
- Remove the supply cassette.
- Remove any media that was bent or crumpled by the carriage shields. Pull one to two feet (30 to 60 cm) of media out of the supply cassette, cut it off and discard.
- Put the supply cassette back into the imagesetter.
- Go to the Pause Screen and load the supply.
- Retry the original operation.

If you cannot unload the media, or the error persists after following this procedure, you can open the imagesetter and try to free the carriage. See the sections *Clear Media from Drum: Access from the Left* and *Clear Media from Drum: Access from the Right* in Chapter 7.

If you cannot correct the problem, call for service.

Overriding Error 44: Cut Not Allowed

When you press Cut in the Utilities Screen, the imagesetter checks to make sure that at least 5" (12.7 cm) has been fed past the cutter. Message 44, Cut Not Allowed, appears if not enough media has been fed.

You can clear this message and get the imagesetter to make the cut without advancing media. Follow these steps:

- Step 1. Go to the Utilities Screen.
- Step 2. Press Cut then Accept.
- Step 3. When message 44 appears, press Pause. You return to the Utilities Screen.
- Step 4. Immediately press Cut then Accept again.

Note: Use this override only if you are absolutely sure that at least 5" (12.7 cm) of media is past the cutter. If the cut produces a sliver of media less than 5" long, you may have trouble removing it.

Remote Diagnostics

The imagesetter can be set up with an internal modem to communicate with a remote diagnostic computer.

To activate the modem and have it dial out to the remote diagnostic computer, press the Dial Out icon button that appears when the system is booting up.

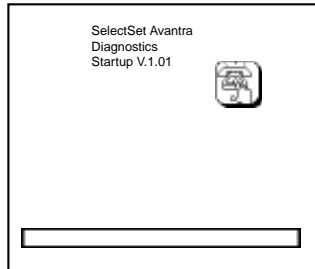

While the modem is active, the control panel looks like this:



Caution:

Never turn off the imagesetter while the modem is active. Doing so could damage the imagesetter operating software.

Boot Errors

The SelectSet Avantra runs a diagnostic program as it boots up. If the diagnostic program detects an error:

- When the internal modem is connected, the imagesetter automatically dials out to the remote diagnostic unit.
- When the internal modem is not connected, the error icon remains on the control panel.
- In either case, the imagesetter will not complete its bootup.

Note: If your modem is not connected, write down the error message and call your service representative.

Boot errors are described as either *fatal* or *nonfatal*.

- Fatal errors make it impossible for the system to boot until some kind of service is performed to correct the problem.
- Nonfatal errors indicate a problem that needs to be corrected, but will not keep the imagesetter from working.

Bypassing Boot Errors

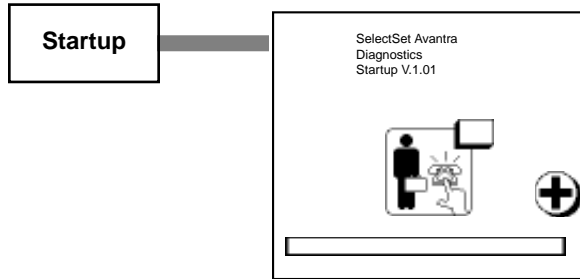

Press Plus to bypass the boot error.

Follow this procedure to bypass boot errors.

1. Restart the imagesetter.
2. When the boot error is detected, an error icon and the Plus icon button appear on the screen.
3. Press Plus within ten seconds. The imagesetter will attempt to complete its bootup.

Chapter 7:
Maintenance and
Troubleshooting

Introduction

This chapter contains:

- Procedures for clearing media jams.
- Basic maintenance procedures.

Clearing Media Jams

Media may get jammed in places that you cannot normally reach. This section describes how to reach all parts of the media path.

Caution:

Before you reach into the imagesetter, remove watches, rings, and any other jewelry that might nick the inner surfaces of the imagesetter. Take special care when working around the drum area.

Remove Nip Drive Assembly

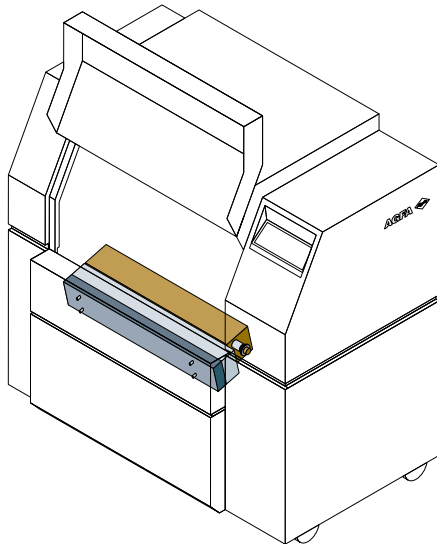

Figure 7.1. Front view showing location of the nip drive assembly.

WARNING:

The nip drive assembly weighs approximately seven pounds (3.2 kilograms).

- Step 1: Turn off the imagesetter.
- Step 2: Open both the left and right side doors.
- Step 3: Remove the front cover.
- Hold on tightly to the top edge of the cover and pull it away from the imagesetter.
 - With the cover leaning away from the imagesetter, lift it up and off the imagesetter.
 - Move the cover out of the way.
- Step 4: Remove the nip drive light shield.
- Four knurled screws hold the shield in place. Remove them.
 - Move the shield out of the way.
- Step 5: Remove the nip drive assembly. See Figure 7.2.

Caution:

Handle the nip drive assembly carefully. Four wires run from the right end of the assembly into the imagesetter. If you drop the assembly or handle it roughly, these wires may be damaged.

- Disconnect the wires at the top of the assembly.
- Loosen the four knurled screws that hold the assembly in place.
- Support the nip drive assembly so that it does not drop when the screws are completely loosened.
- Put the assembly out of the way on a secure flat surface.

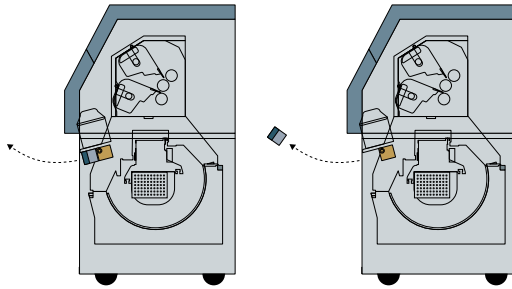

Figure 7.2. Remove the nip drive assembly.

- Step 6:** Clear any media fragments out of the media path.
- Step 7:** Put the nip drive assembly back in place.
- Line up the locating pins on the back of the assembly with those on the mounting plate.
 - Tighten the screws.
 - Reconnect the wires.
- Step 8:** Put the light shield back in place.
- Step 9:** Put the front cover back on the imagesetter and close both side doors.
- Step 10:** Start the imagesetter and resume operations.

Clear Media from Drum: Access from the Left

Step 1: Turn off the imagesetter.

Step 2: Open the left side door.

Step 3: Remove the left drum cover.

- Loosen the four latches that hold it in place.

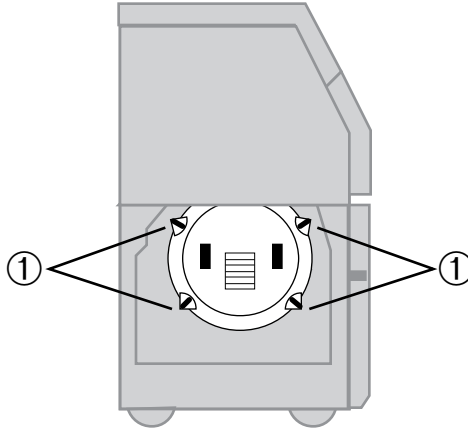

Figure 7.3. The imagesetter with the left side door open showing the drum cover.

①—Latches. Pull and turn to loosen.

Step 4: Pull the carriage as far as possible toward the open door.

- When you pull the carriage, grasp only the solid metal surfaces. Do not pull wires or other components.

Step 5: Remove the left inner shield.

- The inner shield is attached to the bottom of the carriage. Rails on top of the shield fit into tracks built into the carriage.
- Pull the shield gently but firmly to remove it from the carriage. Grasp the shield by the two built-in vertical ridges.
- When the shield is out, put it on a clean surface.

Step 6: Clear the media path.

Step 7: Replace the left inner shield.

- Line up the inner shield with the imaging drum. The left side of the left inner shield rises higher than the right.
- Line up the rails on the shield with the tracks in the carriage.
- Gently but firmly push the shield about 1" (2.5 cm) onto the carriage.
- On the left side of the shield is a plastic strip. Press down the leading edge of this strip so that it does not bend as you slide the shield back onto the carriage.
- There are metal stops on both the shield and the carriage. Push the inner shield all the way onto the carriage, until the stops on the shield touch those on the carriage.

Step 8: Put the drum cover back on and secure the latches.

Step 9: Close the left side door and start the imagesetter.

Clear Media from Drum: Access from the Right

Step 1: Turn off the imagesetter.

Step 2: Open the right side door.

Step 3: Remove the right drum cover.

- Loosen the four latches that hold it in place.

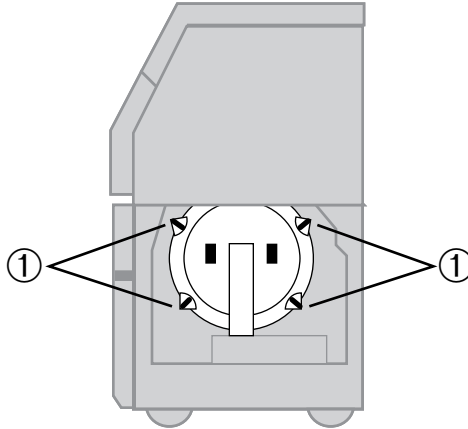

Figure 7.4. The imagesetter with the right side door open showing the drum cover.

①—Latches. Pull and turn to loosen.

Step 4: Pull the carriage as far as possible toward the open door.

- When you pull the carriage, grasp only the solid metal surfaces. Do not pull wires or other components.

Step 5: Remove the right inner shield.

- The inner shield is attached to the bottom of the carriage. Rails on top of the shield fit into tracks built into the carriage.
- Pull the shield gently but firmly to remove it from the carriage. Grasp the shield by the two built-in vertical ridges.
- When the shield is out, put it on a clean surface.

Step 6: Clear the media path.

Step 7: Replace the right inner shield.

- Line up the inner shield with the imaging drum. The right side of the right inner shield rises higher than the left.
- Line up the rails on the shield with the tracks in the carriage.
- Gently but firmly push the shield about 1" (2.5 cm) onto the carriage.
- On the right side of the shield is a plastic strip. Press down the leading edge of this strip so that it is not damaged as you slide the shield back onto the carriage.
- There are metal stops on both the shield and the carriage. Push the inner shield all the way onto the carriage, until the stops on the shield touch those on the carriage.

Step 8: Put the drum cover back on and secure the latches.

Step 9: Close the right side door and start the imagesetter.

Clear Media from Input Side

Step 1: Turn off the imagesetter.

Step 2: Raise the top cover.

- If your imagesetter is equipped with an on-line bridge, lift the bridge up and out of the way.

Step 3: Remove the plastic light shield that covers the front of the media supply area.

- The light shield pivots on two metal pins in the media compartment. Raise the light shield.
- There is an open slot in the light shield at the left pivot point. Raise the shield so that this opening lines up with the flat sides of the metal pin.
- Lift the left side of the light shield up and off the left pin, then slide the right side off the right pin.

Step 4: Remove the light shield that covers the rear of the media supply area.

- Lift it straight up and out of the imagesetter.

Step 5: Remove the light shield that covers the media path.

- Loosen the six latches that hold the shield in place.
- There is a handle in the center of the shield.
- Hold the shield by the handle and slide it up toward the top of the imagesetter.
- Lift the shield so the bottom is free, then slide the shield down to free the top edge.
- Lift the light shield out of the imagesetter and move it out of the way.

Step 6: Clear the media path.

Step 7: Replace the media path light shield. Be sure to tighten all six latches that hold the light shield in place.

Step 8: Replace the light shield that covers the rear of the media supply area.

Step 9: Replace the light shield that covers the front of the media supply area.

Note: If the shield does not close all the way, do not force it into position. Instead, slide it the the left or right on the metal pins until you get it into the correct position.

Step 10: Start the imagesetter and resume operations.

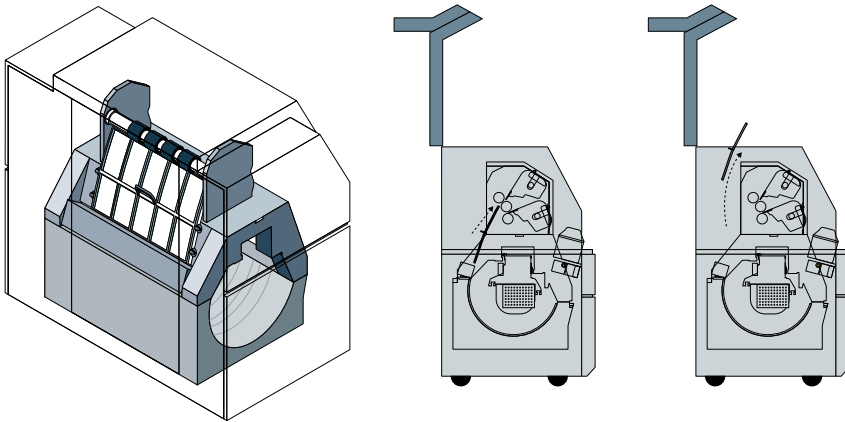

Figure 7.5. Left, view of the imagesetter showing location of the light shields and latches. Right, removing the light shield.

Maintenance

The only maintenance you need to perform on your SelectSet Avantra is to keep it clean. To help keep your imagesetter clean, keep your work area as clean as possible.

Follow these guidelines when cleaning the inside of the imagesetter:

- When using a vacuum cleaner:
 - Use an attachment with soft bristles.
 - Make sure that the attachment is clean.
 - Do not use attachments made of metal or hard plastic. These can damage the interior surfaces of the imagesetter.
- When dusting:
 - Use only a clean, dry, lint free cloth to wipe interior surfaces.
 - Do not use cleaning agents of any kind inside the imagesetter.

Exterior

Clean the exterior of the imagesetter as required.

- Exterior panels: Use a damp cloth. If necessary, use mild soap as a cleaning agent.
- Control panel: Use a damp cloth.

Interior

Clean the Take-up Cassette and the Supply Cassette compartments.

Interval: Every two weeks

Method: Vacuum or wipe clean.

Supply Cassettes

Clean the inside of supply cassettes.

Interval: Every time you load media.

Method: Vacuum or wipe clean.

Take-up Cassettes

Clean the inside of take-up cassettes.

Interval: Once a month.

Method: Vacuum or wipe clean. Open the take-up cassette by removing the four screws that hold the lid and base together.

Supply Rollers

Clean the surface of the supply rollers in the media supply compartment.

Interval: Once a week or as dirt and contamination is observed on the rollers.

Method: Remove supply cassettes. Use plastic packing tape. Wrap tape around your hand with the sticky side out and press against the rollers to pick up dirt. Adhesive rollers for removing lint from clothing can also be used.

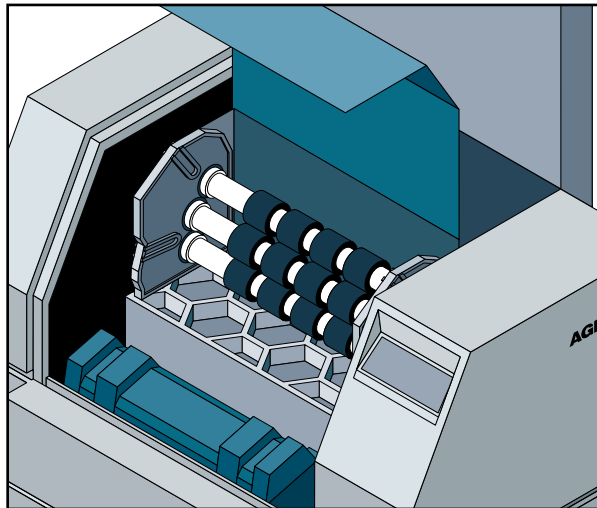

Figure 7.6. Supply rollers in the media compartment.

Intake Filters

Check both the Electronics Enclosure Intake filter and the Drum Intake filter every day to make sure they are not blocked.

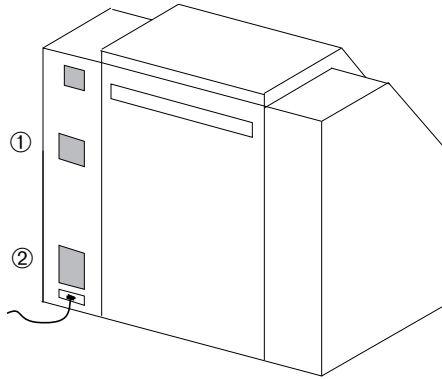

Figure 7.7. ① —Electronics enclosure filter. ② —Drum intake filter.

Clean the Electronics Enclosure Intake filter. This filter is approximately $\frac{1}{4}$ " (6 mm) and made of black plastic foam.

Interval: Weekly.

Method: Shut down the imagesetter. Pull out the filter and vacuum.

Replace the Drum Intake filter. This filter is approximately $\frac{3}{4}$ " (19 mm) thick and is made of several different layers.

Interval: Once a month or more frequently if necessary.

Method: Shut down the imagesetter. Pull out the filter and replace it. Use part number C00305-001. Contact your service provider for information about ordering replacement filters.

Punch Trays

Check the punch trays every three months. Follow this procedure to empty them.

Step 1: Turn off the imagesetter.

Step 2: Open the left side door.

Step 3: There are two punch trays, both below the imaging drum. They are bright red. Slide the trays out of the imagesetter to empty them.

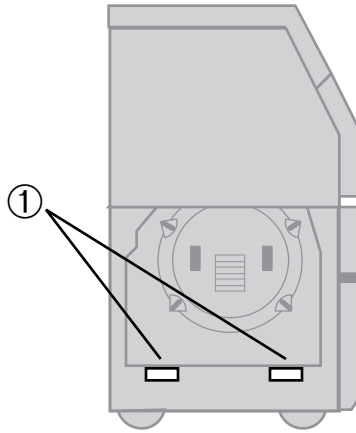

Figure 7.8. The imagesetter with the left side door open.

①—The punch trays.

Step 4: Replace the trays, close the left side door and start the imagesetter.

Chapter 8:
Avantra 20/25 OLP
Bridge Operation

Introduction

This section describes the media transport or bridge section of the Avantra 20/25 OLP. It contains the following information:

- Description and overview of the entire Avantra 20/25 OLP unit.
- How to set up the SelectSet Avantra to work with an on line processor.
- The operating sequence that the bridge follows.
- How to deactivate the bridge and use a take-up cassette.
- How to clear media jams in the bridge.

Product Description

The SelectSet Avantra 20/25 OLP consists of:

- A transport mechanism that feeds exposed media from the image-setter to the processor. This is called the *bridge*. The bridge also provides the communication link between the processor and the imagesetter.
- A media processor attached to the imagesetter.

Status and error messages from the bridge appear on the SelectSet Avantra control panel. These errors and the methods to correct them are described in *Chapter 6: Diagnostics and Error Messages*.

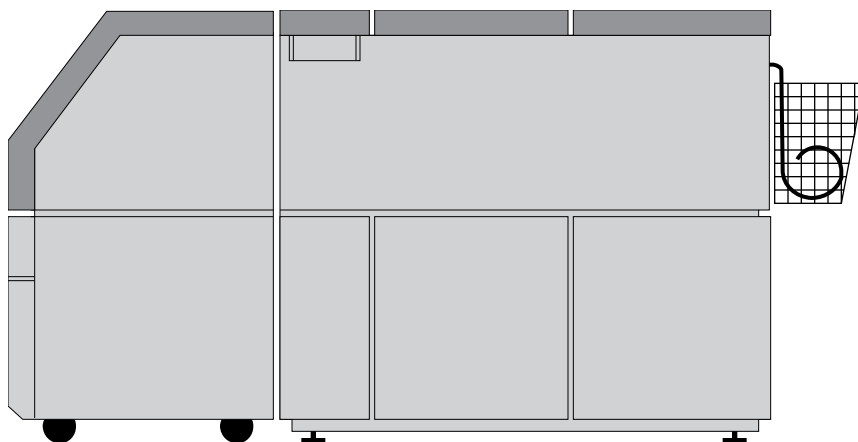

Figure 8.1. Exterior view of the SelectSet Avantra and OLP

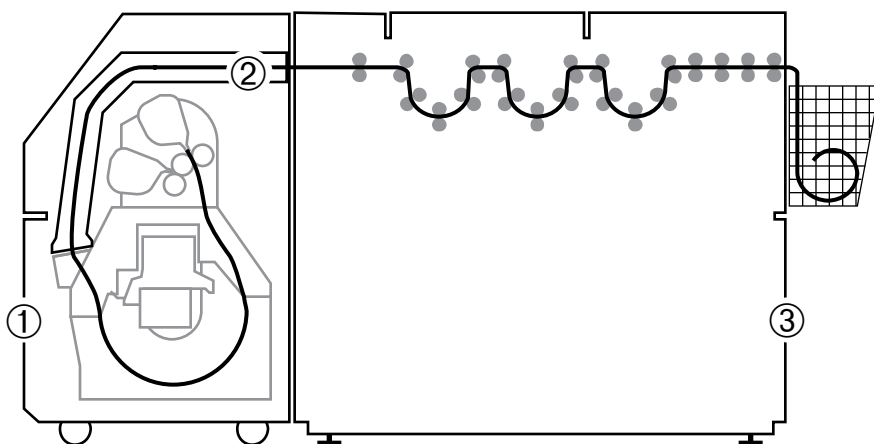
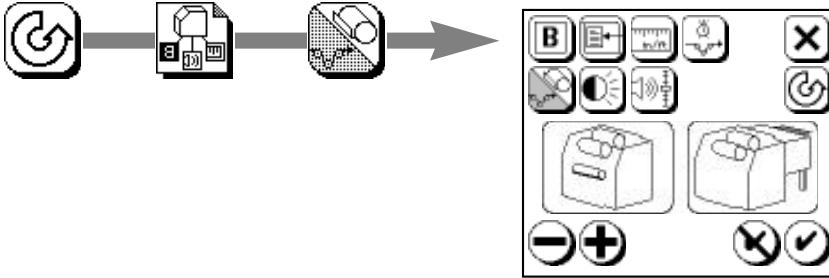

Figure 8.2. Cutaway view of the SelectSet Avantra and OLP showing the media path.
①—Imagesetter. ②—Bridge. ③—Processor.

Set Up the Processor Option

Follow this procedure to set up the imagesetter to use the OLP.

1. Press Pause, Configuration, Output Mode.



2. Select the output mode:

 Press Plus or Minus to select output mode.

Choices:

 Take-up cassette (left)
OLP (right)

3. Accept or Cancel:

 Press Accept to change the output mode, or...

 ...press Cancel to discard.

The button shows the current output mode.

 Take-up cassette selected.

 OLP selected.

Note: Make sure that you remove the take-up cassette and that the bridge is completely lowered into its operating position.

Special Points to Remember

Keep these points in mind when you select on-line processor output mode.

- The imagesetter disregards the interpage gap amount specified in the Feed Amounts Screen. Instead, it uses a value of .8 inches (2 cm).
- If there is imaged media in the drum and you unload a media supply, the imagesetter performs a feed and cut, then sends the cut piece to the bridge.
- To conserve media, the imagesetter is programmed to leave the last imaged job in the drum. Activate the Processor Timeout function in the Configuration Screen to program the imagesetter to feed, cut, and process this job.
- If an error occurs while the imagesetter is feeding media to the bridge, the following job may be delayed slightly as the imagesetter moves media to recover from the error.

Bridge Operating Sequence

Here is what happens when you use the bridge.

- The imagesetter cuts media as soon as possible after it has fed 10" (25.4 cm) past the cutter.
- This minimum length can be made up of imaged jobs, unexposed media feeds, or both.
- Cuts are made automatically when the imagesetter is idle.
- When the imagesetter advances media because a new job or feed command has been sent by the RIP, it switches to the Pause Screen and displays this animated icon.

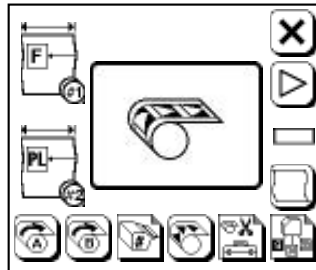

- If a media feed pushes enough media past the cutter to enable a cut, the Pause Screen remains on the control panel and this animated icon appears.

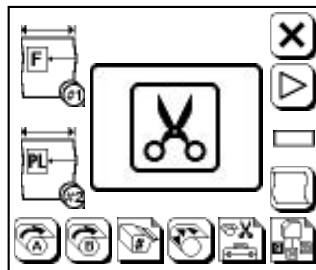

- When you go to the Pause Screen to perform feed or cut operations yourself, the imagesetter may have to delay these actions if media is already moving onto the bridge. In such cases, the icon in the bottom left corner of the Pause Screen changes. The changed icon flashes until the cut media has advanced far enough onto the bridge to leave room for the piece about to be cut.

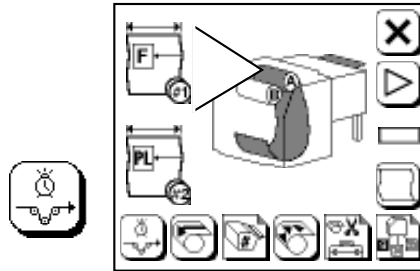

- This icon also flashes briefly on the screen when the imagesetter automatically feeds and cuts media.

To Optimize Output

Avoid sending short jobs (less than 10" or 25.4 cm) immediately before long jobs.

For example, if you image a 20" job after a job that is shorter than 10", the media cut produces a piece approaching 30" long. The imagesetter waits until this media clears the bridge before it resumes imaging.

To avoid this idle time between jobs, you can:

- Plan your output so that you queue short jobs together and long jobs together.
- Feed a small amount of media (enough to make the 10"/25.4 cm minimum cut length) after a short job when the next job is long.

Clearing the Bridge Media Path

The bridge is covered by two access panels. You can take these panels off to reach the bridge media path.

Sensors in the bridge monitor the position of a piece of media as it travels through the bridge. If the sensors detect a media jam, the error message that appears on the imagesetter control panel helps you determine where to look to clear the problem.

Removing the Bridge Access Panels

- The bridge has two access panels.
- Both are held in place by four screws. The screws are attached so that they cannot fall out of the panel when they have been loosened.
- The panels interlock. You need to remove the top panel before you can remove the lower panel.
- Rollers inside the bridge guide the media.
- These rollers can move in one direction only—toward the processor. Keep this in mind if you are about to pull a piece of media out of the bridge.

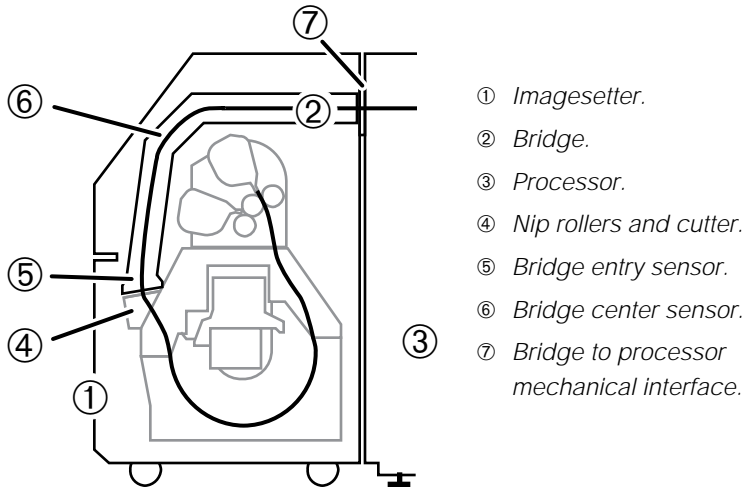

Figure 8.3. Cutaway view showing key parts of the media path through the bridge.

Bypassing the Bridge

You may need to use the standard take-up cassette instead of the bridge. Follow these steps.

Step 1. In the Configuration Screen, change the output mode from on-line processor to take-up cassette.

Note: You must change the Output Mode selection in the Configuration Screen. If you use the take-up cassette while on-line processor is specified as the output mode, the imagesetter will report a media jam when it advances media.

Step 2. Open the outer covers, lift up the bridge, and put the take-up cassette into the imagesetter.

Step 3. Lower the bridge. Rubber “feet” at the bottom of the bridge rest on top of the take-up cassette.

Step 4. Close the outer covers and send jobs to the imagesetter. When your jobs are complete, feed and cut the media, remove the cassette, and process the media.

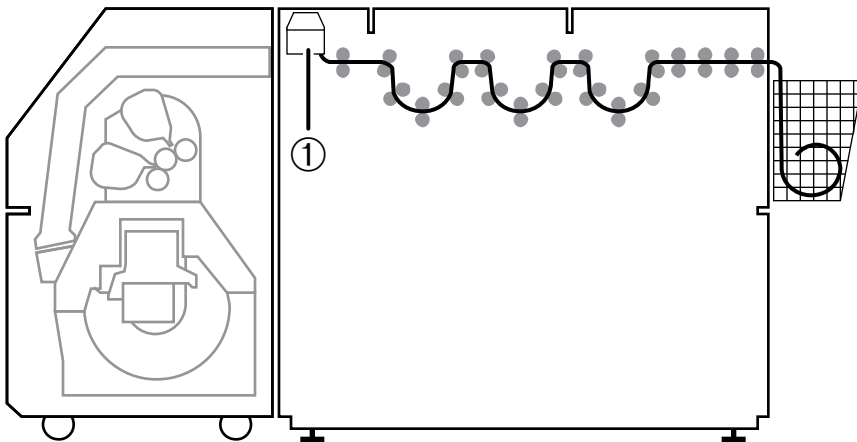

Figure 8.4. You can put the standard take-up cassette ① into the processor to bypass the bridge.

Chapter 9:
Avantra 20/25 OLP
Processor Operation

Introduction

This section describes the media processor section of the Avantara 20/25 OLP. It contains the following information:

- The use of the Avantara 20/25 OLP Control panel.
- How to set times, temperatures, replenishment rates, and various other functions.

Also provided is a table that you can use to record your nine preferred operating programs

When your processor is first installed, a service representative sets up your system. The procedures in this chapter are provided to give you more flexibility on how you can use your equipment.

Processor Description

The Avantra 20/25 OLP processor provides rapid access processing for a wide variety of photographic materials.

Features

- Types of media: paper, film, and plate material.
- Adjustable time and temperature controls.
- Handles media up to 20 inches (51 cm) wide.
- Microprocessor driven control board monitors process time, temperature, replenishment, chemistry level, and communication with the Media Bridge.
- Sensors monitor media continuously during processing.
- Store up to nine different programs to ensure consistent processing of repetitive jobs.

Starting the Processor

You can power the processor On/Off manually or automatically.

- **Manual On/Off:**
Press ON/OFF to start the processor.
- **Auto On/Off:**
You can program the processor to turn on and off at specified times. See the section *Auto On/Off* in this chapter.

The Processor Control Panel

The control panel consists of the following:

- **Display:** An LED display that shows status and error messages
- **Alarm signals:** LED warning lights that appear below the display
- **Status signals:** LED lights that appear below the display
- **Function keys:** Twenty-three keys, used for programming the processor

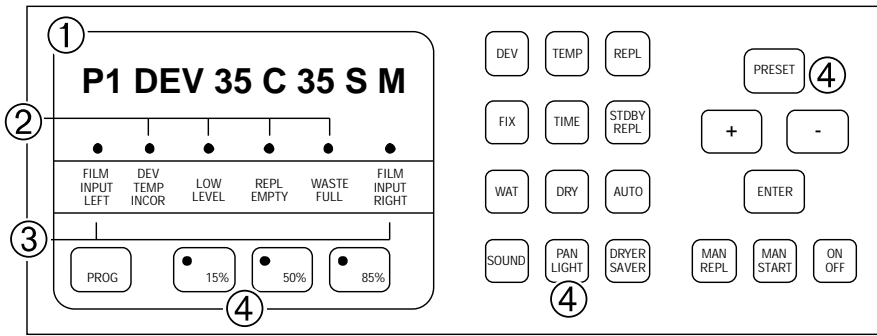

Figure 9.1. The processor control panel.

① Control panel display. ② Alarm signals. ③ Status signals. ④ Function keys.

Idle State

P1	Current program	Program 1 is selected.
DEV 35 C	Developer temperature	35° centigrade.(Actual)
35 S	Developer time	35 seconds.
M	On/Off mode	M=Manual On/Off; A=Auto On/Off

This display appears when the processor is ready to process media.

Note: This is just an example. The actual numbers that appear on your display may vary if you specify different parameters.

As you perform different functions with the processor, the message in the display changes. This display returns automatically after you complete the different functions.

For example:

- Press DEV, then TEMP. The display changes to
DEV TEMP 35C.
- After about ten seconds, the display automatically returns to:
P1 DEV 35 C 35 S M

Run State

- **Job in Bridge:** As soon as imaging begins, “Job in Bridge” displays. This message replaces the Idle State Display. The Idle State Display may be viewed by pressing the “Enter” key (and remains displayed for five seconds).
- **Job in Proces:** After the media has completed transport into the processor and no new job has started imaging, the display will change to “Job in Proces”. The Idle State Display may be viewed by pressing the “Enter” key (and remains displayed for five seconds).

Alarm Signals

Alarm signals appear as flashing red LEDs below the display. They indicate:

- **Dev. Temp. Incor.:** Developer temperature too high or low
- **Low Level:** Low level in the developer or fix tanks
- **Repl. Empty:** Low level in the replenishment containers
- **Waste Full:** N/A

The SelectSet Avantara displays error 27, Processor Alarm Signal when any of these errors occur. In this case, the imagesetter finishes the current job, but will not image another job or advance media until you clear the processor error. As soon as you correct the error, the error at the imagesetter is cleared.

Note: When you adjust the processor to clear a Dev. Temp.. Incor. alarm, the imagesetter waits until the developer has been at the correct temperature for about one minute before the error 27 message is cleared.

Status Signals

Status signals appear as solid red LEDs below the display. They indicate:

- **Film Input Left:** Media is entering the processor
- **Film Input Right:** Media is entering the processor

Function Keys

Function keys enable you to view and change parameters for the different processor operations.

Automatic Functions

The processor performs these functions automatically after you turn it on:

- Jog Function
- Automatic Start and Stop

Jog Function

Every five minutes, when the processor is on but not processing media, an internal timer activates these functions for one minute:

1. The roller transport motor.
2. The circulation pumps for developer and fixer.

The jog function prevents crystallization on the rollers in the developer and fixer racks.

Note: The Jog Function is also active in the Standby Mode.

Automatic Start and Stop

When media is fed into the processor, the input sensors automatically activate the following functions:

1. The roller transport motor.
2. The circulation pumps for developer and fixer.
3. The magnetic valve for wash water.
4. The blower and heating elements in the dryer section.

When the trailing edge of the media exits the dryer and passes the last internal sensor, these functions automatically stop.

System Clock

The processor has an internal clock that runs continuously, even when the processor is off. This clock is used to turn the processor on and off automatically and to control standby replenishment.

The internal clock operates in a 24 hour mode. For example, 5:00 PM is shown as 17:00 hours.

Time Conversion Table

AM	24 Hour	PM	24 Hour
12:00 Midnight	00:00	12:00 Noon	12:00
1:00 AM	01:00	1:00 PM	13:00
2:00 AM	02:00	2:00 PM	14:00
3:00 AM	03:00	3:00 PM	15:00
4:00 AM	04:00	4:00 PM	16:00
5:00 AM	05:00	5:00 PM	17:00
6:00 AM	06:00	6:00 PM	18:00
7:00 AM	07:00	7:00 PM	19:00
8:00 AM	08:00	8:00 PM	20:00
9:00 AM	09:00	9:00 PM	21:00
10:00 AM	10:00	10:00 PM	22:00
11:00 AM	11:00	11:00 PM	23:00

Changing the Time

Press **TIME** to display the current day and time. For example:

MON 10:39

Follow this procedure to change the settings.

- Step 1: Press **TIME** then **PRESET**. The display shows the current day setting.
- Step 2: To change the day, press plus (+) or minus (-).
- Step 3: Press **ENTER**. This displays the current hour setting.
- Step 4: To change the hour, press plus (+) or minus (-).
- Step 5: Press **ENTER**. This displays the current minute setting.
- Step 6: To change the minute setting, press plus (+) or minus (-).
- Step 7: Press **ENTER** to store the changes.

Auto On/Off

You can set up the processor to turn itself on and off automatically at specific times, or you can turn it on and off manually.

Select On/Off Mode, Display On/Off Time

Pressing the AUTO key:

1. Displays the current auto on time.
2. Switches between auto and manual on/off.

Follow this procedure:

Step 1: Note the current control panel display. For example:

P1 DEV 35 C 35 S A

(A at the right means that the auto mode is selected.)

Step 2: Press AUTO. The current auto on time appears. For example:

MO-FR 8:00

Step 3: After about ten seconds, the standard display returns. Note that the last letter has changed. For example:

P1 DEV 35 C 35 S M

(M at the right means that manual mode is selected.)

Setting On and Off Time

Step 1: Press Auto. The current auto on time appears.

Step 2: Press Preset. The display reads MO-FR.

Step 3: To change the day, press plus (+) or minus (-).

Step 4: Press Enter. This displays the current hour setting.

Step 5: To change the hour, press plus (+) or minus (-).

Step 6: Press Enter. This displays the current minute setting.

Step 7: To change the minute setting, press plus (+) or minus (-).

Step 8: Press Enter to store the changes.

Step 9: Press Enter. This displays the off setting.

Step 10: To change the hour, press plus (+) or minus (-).

Step 11: Press Enter. This displays the current minute setting.

Step 12: To change the minute setting, press plus (+) or minus (-).

Step 13: Press Enter to store the changes.

Note: If you select auto on/off without setting an off time, the processor defaults to 12:00 AM for the off time, assuming that the system clock is set correctly.

Checking the On/Off Selection

If you intend to use auto on/off after you set the times, check the control panel display to make sure that auto on/off is active.

- When manual on/off is active, the control panel display shows the letter M at the right. For example:
P1 DEV 35 C 20 SEC M
- When auto on/off is active, the control panel display shows the letter A at the right. For example:
P1 DEV 35 C 20 SEC A

Checking Preset Values

You can check any preset value at any time.

For example, to check the fixer temperature and compare it with the preset value, follow these steps:

Step 1: Press Fix and Temp.

- The actual fixer temperature appears. For example:

FIX TEMP 33 C

Step 2: Press Preset while the actual temperature is displayed.

- The preset fixer temperature appears. For example:

FIX SET 35 C

Step 3: If required, press plus (+) or minus (-) to change the setting.

Step 4: Press Enter to store the setting that appears on the display.

Changing the Developer Time

Follow these steps to change the developer time.

Step 1: Press DEV and TIME.

- The current developer time appears. For example:

DEV TIME 16 SEC

Step 2: Press PRESET.

- The preset developer time appears. For example:

DEV SET 16 SEC

Step 3: Press plus (+) or minus (-) to change the setting.

Step 4: Press ENTER to store the setting that appears on the display.

Range for Developer Time: 10 to 60 seconds.

Changing Temperature

Follow this procedure to change the developer temperature.

Step 1: Press DEV TEMP.

- The actual developer temperature appears. For example:
DEV TEMP 32 C

Step 2: Press PRESET.

- The preset developer temperature appears. For example:
DEV SET 32 C

Step 3: Press plus (+) or minus (-) to change the setting.

Step 4: Press ENTER to store the setting that appears on the display.

To adjust fixer or dryer temperature, press FIX or DRY instead of DEV in Step 1.

Range for Developer and Fixer Temp.: 23–43° C.

Range for Dryer Temp.: 30–60° C.

Changing Replenishment Rates

Follow this procedure to change the replenishment rate.

Step 1: Press DEV and REPL.

- The current developer replenishment rate appears. For example:

DEV REPL 200 CC

Step 2: Press PRESET.

- The preset rate appears. For example:

DEV SET 200 CC

Step 3: Press plus (+) or minus (-) to change the setting.

Step 4: Press ENTER to store the setting that appears on the display.

To adjust fixer replenishment, press FIX instead of DEV in Step1.

Range for Developer and Fixer Replenishment: 10–999 ml.

Standby Replenishment

Standby replenishment compensates for exhaustion of the developer due to oxidation and depletion of the fixer due to evaporation.

The replenishment pump releases 100 cc. of chemistry each time it is activated. You specify the amount of replenishment required for an entire day. The processor calculates the interval required between each pulse of fresh chemistry.

Standby replenishment is active continuously, as long as the processor is plugged in to the power supply. Replenishment continues even if you shut the processor off with the ON/OFF function key.

Follow this procedure to change the standby replenishment rate:

Step 1: Press DEV and STDBY REPL. The current standby replenishment rate appears. For example:

DEV STDBY 1500 CC

Step 2: Press PRESET.

Step 3: Press plus (+) or minus (-) to change the setting.

Step 4: Press Enter to store the new value.

To change the standby replenishment rate for fixer, press FIX instead of DEV in Step 1.

The fixer replenishment rate needs to be set high enough to maintain the level in the fix tank.

Range for Fixer STDBY Repl.: 0 - 2000 ml

Range for Developer STDBY Repl.: 0 - 2000 ml

Other Functions

Sound

Press SOUND to switch the audible “beep” on or off.

The “beep” sounds when the trailing edge of the material being processed clears the film input sensor. This signal also indicates that you can insert the next piece of media to be processed.

Pan Light

Controls the brightness of the LED display. There are two modes: maximum and adjustable. In the maximum mode, the LED level is set to maximum light intensity. The adjustable mode allows you to change the intensity between the maximum and minimum (turned off).

Note: Use the minimum setting for Panchromatic materials in darkroom environment.

Follow this procedure to adjust the LED intensity level:

Step 1: Press PAN LIGHT and PRESET.

Step 2: Press plus (+) or minus (-).

Step 3: When you reach the LED intensity you want on the control panel, press Enter.

After you preset the adjustable level, you can switch between maximum and the adjusted level by pressing PAN LIGHT several times.

Dryer Saver

When this function is On (the default setting), the dryer is in standby mode. When switched to Off, the display reads DRYER SAVER OFF and the heating elements and dryer run continuously at the preset temperature.

Man. Repl.

Controls manual replenishment of developer and fixer. When you press MAN REPL, 100 cc. of both developer and fixer are pumped into the tanks.

Man. Start

Press MAN START to start up the drive motor, the circulation pumps, and the dryer. The display reads P x MANUAL START, where x is the number of the selected program. For example, P1 MANUAL START. Press the MAN START again to return to the ready/idle mode.

Note: No replenisher is released in MAN START mode.

Density 15%, 50%, 85%

Replenisher quantities for developer and fixer are calculated according to a formula based on the preset value, the area of the material (width x length), the percentage density, and the replenisher information (cc. per square meter). This last information is listed on the material box or in documentation provided by the media manufacturer. The formulas are as follows:

Devel. Repl. = (cc. / meters²) x meters² x (Density / 50%).

Fixer Repl. = (cc. / meters²) x meters² x (100% - Density) / 50%.

50% is the default value whenever the processor is turned on. The replenishment quantity is based on a 50% density and the following formulas are stored in the microcomputer:

DENSITY	DEVEL.	FIXER
15%	0.3 x calc. value	1.7 x calc. value
50%	Calculated value	Calculated value
85%	1.7 x calc. value	0.3 x calc. value

Offline Operation

You can bypass the bridge and feed media directly into the processor from a take-up cassette.

Built into the front of the processor is a lid. Below the lid is an input tray with various foam light seal adapters, for use with different size take-up cassettes.

Follow this procedure.

- Step 1: Raise the input lid.
- Step 2: Select the appropriate adapter for the take-up cassette you are using.
- Step 3: Pull approximately 6 to 8 inches (15.2 to 20.3 cm) of media from the cassette as a leader.
- Step 4: Start the leader in the input slot while observing the indicators of the OLP. Ensure that the indicators activate (Film Input Left, Film Input Right).
- Step 5: Lower the cassette fully into the foam adapter.

Note: The input lid of the processor must remain open while using this feature. This generates error 59, Processor Top Door Open on the imagesetter control panel. This message automatically clears as soon as you close the lid.

- Step 6: If you get an “Input Jam” message at the processor after placing the cassette onto the adapter and observing the Film Input indicators, the leader was not long enough. The media reached the Input Sensors but not the rollers. Remove the cassette and pull an additional 2 inches (5.1 cm) of media from the cassette. Clear the error by pressing the processor On/Off key and re-insert the media.

Programming

The processor can store nine different programs that control developing time, dryer temperature, and and replenishment rates.

Programs 1, 2, and 3 are preset with the values listed below.

Preset Values			
Function (Unit)	Program 1	Program 2	Program 3
Dev. time (sec.)	30	30	40
Dev. temp. (°C)	25	25	25
Fix. temp. (°C)	23	23	23
Dry temp. (°C)	50	45	40
Dev. repl. (cc/m2)	250	250	250
Fix. repl. (cc/m2)	375	375	375
Dev. stdby. (cc/24hr.)	1000	1000	1000
Fix. stdby. (cc/24hr.)	1000	1000	1000

Note: Programs 4 through 9 are identical to Program 3.

Selecting Programs

Press PROG to select a different program.

Each time you press PROG, the next program is selected. The program number appears on the left side of the control panel display. You scroll through the programs in numerical order.

Revising Programs

Any changes you make to the preset values are stored as part of the current program. For example, if you have selected program 2 and you change the dryer temperature, the new temperature is incorporated into program 2.

All nine programs have the same developer and fixer temperatures. For example, if you change the fixer temperature for program 1, all programs use the new fixer temperature.

Note: This table is provided for you to record your preferred operating values.

Preferred Operating Values (Customer Adjustable)

Function (Unit) (Range)	Dev. Time (sec.) (10-60)	Dev. Temp (°C) (24-43)	Fix Temp (°C) (23-43)	Dry Temp (°C) (30-60)	Fix Repl. (cc/m ²) (10-999)	Dev. Repl. (cc/m ²) (0-2000)
Program 1						
Program 2						
Program 3						
Program 4						
Program 5						
Program 6						
Program 7						
Program 8						
Program 9						

Processor Maintenance

This section describes daily, weekly, and monthly maintenance routines. Proper maintenance of your processor is essential to getting the best possible photographic results from your imaging system.

Follow a regular maintenance program. A thorough cleaning at least once a month is strongly recommended.

The frequency of your maintenance program may vary. If your shop runs multiple shifts or high volumes of media, repeat these procedures more frequently.

WARNING:

Always wear adequate protection. Wear rubber gloves, a rubber apron, and goggles when you clean the processor.

Daily Maintenance

Follow this procedure every day before you process any media:

- **Check the replenishment containers.**
Refill containers with fresh chemistry when the level is two inches (5 cm) from the bottom of the container.
- **Check and empty waste containers (if installed).**
When depleted chemistry is four inches (10 cm) from the top of the container, dispose of chemistry and install new waste containers.

Note: Always dispose of developer, fixer, and wash water according to local regulations.

- **Top off chemistry every morning.**
Remove main cover and manually replenish until both developer and fixer are topped off.

- **Wipe down all rollers above the solution level.**
Use a separate rag for developer rollers. A cleaning sheet can be used as an alternative to wiping down the rollers. A cleaning sheet can be any pre-processed media that is at least 18 inches (46 cm) long.
- **Make sure that the water supply is adequate.**
The processor can be equipped with a wash recirculator or a direct water supply. If your system has a wash recirculator, make sure that the water level is high enough. If you use a direct water supply, make sure that the valve feeding the processor is open and that enough water is flowing.
- **Check the development time, temperature, and replenishment settings at the processor.**
Check these settings every time you process media.

Note: To prevent the growth of algae in the wash tank, drain the tank at the end of each day.

Weekly Maintenance

Follow this weekly maintenance procedure:

- **Pull the wash rack and drain the wash section.**
Clean and wipe down the wash tank. If algae buildup is a problem, clean the inside of the tank with bleach and rinse well. Clean the wash roller rack with warm water.

Note: Never put racks on the dryer cover. Chemicals may run into the wiring.
- **Change developer filters.**
Change the developer filter every 40 working hours.
- **Clean the wash recirculator (U.S. Only).**
(Not all systems are equipped with a wash recirculator.) Remove and replace the filter; wipe down the tank and fill with fresh water.

- **Drain the processor.**
Dispose of developer, fixer, and wash water according to local regulations.
- **Drain the filter housing.**
Remove the filter. Change the filter every 40 working hours.
- **Remove roller racks and wipe residue from tanks.**
Use paper towels to remove sludge or residue from tanks.

Note: Never put racks on the dryer cover. Chemicals may run into the wiring.

- **Fill the developer and fixer tanks with warm water.**
Load a container with warm water and put developer and fixer replenishment tubes in the container.
- **Turn on the processor.**
Circulate the water through the pumps and plumbing system for 10 to 15 minutes.
- **Rinse the roller racks and wipe them dry.**
If chemical residue crystallizes on the rollers, scrub gently with a soft bristle brush to remove it.
- **Drain water from developer and fixer tanks and filter housing.**
- **Remove filter housing.**
Clean the inside of the filter housing with paper towels.
- **Install a new filter.**
Replace the filter and housing.
- **Clean the wash tank with water.**
Remove residue with paper towels. Use a soft bristle brush if necessary.
- **Clean the wash recirculator.**
(Not all systems are equipped with a wash recirculator.) Rinse the tank with warm water; use a soft bristle brush if necessary. Change the filter and reload with fresh water.

- **Fill fixer tank.**

Be careful not to splash fixer into the developer tank. When filling tanks without roller racks in place, fill tanks to the line of the drain tube. Wipe up any spills.

CAUTION:

Be careful not to spill any fixer into the developer when lifting the racks out of a full tank. Even a very small amount of fixer will contaminate the developer.

- **Fill the developer tank.**

Always fill the developer tank after the fixer. This is because the fixer tank is buffered to take any minor carry over from the developer tank. Wipe up any spills.

- **Insert roller racks.**

Set processor to manual start mode. To do this, press MAN START. This will make it easier to get the worm gears on the drive shaft to engage properly with the drive gears on the roller racks.

Be careful not to drop racks into the tank. This may cause chemistry to overflow into the adjacent tank.

When you finish installing the racks, press MAN START again to deactivate manual start mode.

- **Make sure that all vapor shields are in place.**

- **Make sure that temperature and speed are set correctly.**

- **Turn on the processor and let it warm up.**

When the “DEV TEMP INCOR” LED is off, the processor is ready to use.

Monthly Maintenance

Once a month, add the following to your weekly maintenance procedure.

- **Pull the developer, fixer and wash roller racks.**
Inspect gears and roller surfaces for wear. Clean each rack with warm water and a soft bristle brush. Rinse thoroughly. Check for disfigured or swollen rollers.
- **Clean drive shaft and worm gear.**
Wipe away any dirt or dried up chemistry.
- **Inspect the dry roller racks.**
Check for contamination buildup. Clean rollers.
- **Make sure that the circulation pumps are working.**
- **Inspect the processor.**
Wipe up any dried chemistry, check hose connections for leaks, etc.

Switches and Sensors

The following illustration provides you with the locations of various Switches and Sensors for use with Status and Error Messages.

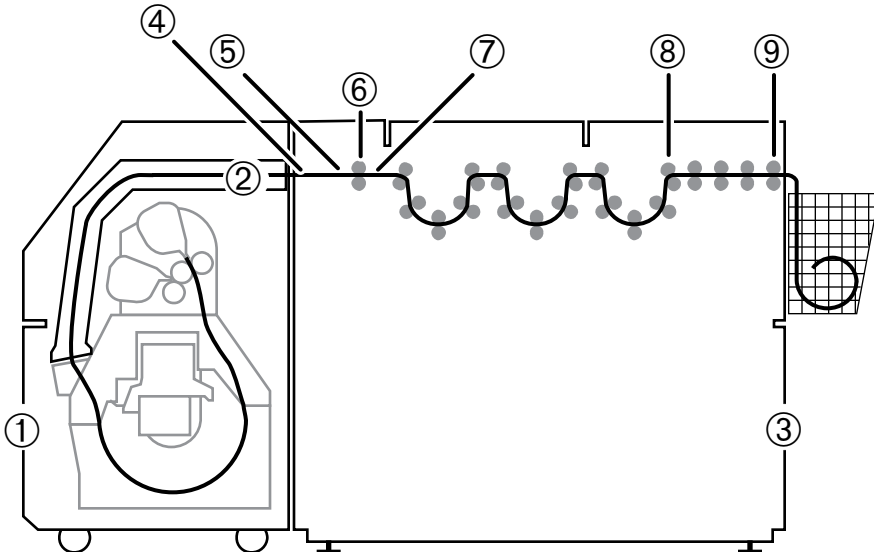

Figure 9.2. The Switches and Sensors

- | | |
|----------------------------|------------------------|
| ① Imagesetter | ⑥ OLP Input rollers |
| ② Bridge | ⑦ OLP Input out sensor |
| ③ Processor | ⑧ Door Open Switch |
| ④ Processor Offline Sensor | ⑨ Exit Sensor |
| ⑤ OLP input sensor | |

Processor Status and Error Messages

This section describes status and error messages that appear on the Avantra 20/25 OLP processor control panel.

Job in Bridge

Meaning: Media is currently in the bridge. There may also be media in the drum being imaged and media in the processor.

Action: No action required. Do not use the processor top door for offline processing while this message appears.

Job in Proces

Meaning: Media is currently in the processor and no new job has started imaging since last piece of media entered the processor.

Action: No action required. Status message only.

Input Jam

Meaning: Media activated the input sensors of the processor, but did not reach the input out sensors in the given amount of time. When the processor displays this message, the imagesetter displays message 57, Processor Error.

Action: Check the processor input rollers for a possible media jam.

Exit Jam

Meaning: Material has entered the processor, but did not reach the processor exit sensor in the given amount of time. When the processor displays this message, the imagesetter displays message 57, Processor Error.

Action: Check processor for possible media jam.

Motor Overload

Meaning: The processor has detected an error in the transport drive system. When the processor displays this message, the imagesetter displays message 57, Processor Error.

Action: Inspect the processor for possible media jam, damaged gears, or binding drive system. Disconnect and reconnect power to the OLP to clear the error. If the error persists, call for service.

Door Open

Meaning: The dryer compartment interlock is disengaged.

Action: Close the dryer compartment door.

Manual Start

Meaning: The manual start key on the control panel has been activated.

Action: As soon as the manual start key is pressed again, the message will automatically be removed.

Appendix A:
Image Quality

Introduction

This appendix provides basic information about photographic principles used by SelectSet Avantra laser imagesetters. It is intended as an introduction for novice operators and as a review for experienced pre-press operators.

The SelectSet Avantra laser imagesetter produces high-resolution type and graphic images. To attain the quality that the SelectSet Avantra can deliver, you need to use the optimum exposure setting for your imaging medium.

Before you begin production, execute and evaluate exposure tests. To maintain high quality standards, repeat this procedure at regular intervals.

Importance of Optimum Exposure

To get the best possible image quality from your SelectSet Avantra, you need to satisfy these two conditions:

1. The developed photographic image has adequate density.
2. The developed photographic image has been given the optimum exposure.

There are many variables in the photographic process. Strict control of the process improves the quality of the output. The more variables you eliminate from the process, the easier it is to control.

Definitions

It is important that you understand these photographic terms before you proceed.

Density

Density is the darkness of a photographic image. It is expressed as a number. The higher the number, the darker the image.

The density of photographic images is affected by:

- **Exposure**
Amount of light that reaches the photographic medium. Changing the exposure changes the density of the processed image.
- **Development**
Changes to the developing conditions (i.e. processor speed, developer temperature), affect the density of the processed image.

Dmax

Dmax is the maximum density that can be found in a photographic image.

Exposure

Exposure is the amount of light that hits the media. As you increase the exposure value, you increase the amount of light that reaches the medium.

- Underexposure
Exposure setting too low; not enough light. Dmax too low; black areas appear gray.
- Overexposure
Exposure setting too high; too much light. Dmax too high; fine screens will fill in, making tone reproduction inaccurate.
- Optimum Exposure
Correct exposure setting. Dmax within correct range.

Development

Development is the chemical process that makes an image appear on exposed photographic material.

Development of the photographic image is affected by:

- The length of time the photographic material is in the developer, controlled by the processor speed.
- Developer temperature.
- Replenishment rate.

Changes to any of these elements affect the density of the processed medium.

For optimum image quality, follow the manufacturer's specifications for processing media. This information is generally provided on a data sheet packaged with each roll of media.

Replenishment

Replenishment is the automatic replacement of the developer solution in a mechanical processor. The developer needs to be replenished because it loses its strength, or becomes exhausted.

Photographic developer becomes exhausted by:

- **Exposure to air**
Ingredients in the developer mix with the oxygen in the air. This process, called oxidation, weakens the developer. The longer the developer sits in a processor, the more exhausted it becomes.
- **Development**
Ingredients in the developer are used up in the chemical reaction that creates the photographic image. The more media you process, the more the developer becomes exhausted.

Replenishment rates for media processors are controlled two ways:

- **Anti-oxidation or AOX function**
Compensates for exposure to air; built into most processors.
- **Developer replenishment setting**
Compensates for amount of media processed. On some processors, you can adjust this rate; others require adjustment by a service representative.

For more information, consult the user documentation for your processor or the manufacturer.

Note: Film requires higher amounts of replenishment than paper because it contains more silver. When you use both film and paper daily in your production environment, it is recommended that you set your processor to the replenishment rate for film. Under-replenishment for film will not produce adequate working density. Over-replenishment for paper does not harm the end result.

Guidelines for Quality

To maintain quality standards, consistent processing of your medium is essential. Follow these guidelines:

- Process your photographic media and maintain your processor strictly according to the manufacturer's specifications.
- Adjust the exposure setting to fine-tune the density of your output.

By following these guidelines, you systematically control the variables associated with developing photographic materials. This leaves exposure as the one variable to fine-tune the density of your output.

To consistently get optimum results, it is essential that you follow these guidelines.

Appendix B:
Tips and Tricks

Introduction

This appendix provides a variety of information that may be helpful as you use the SelectSet Avantara. Topics include:

- Special operating sequence that the imagesetter uses when you specify plate as the imaging media.
- Using the Switch Supplies function in the Utilities Screen.
- Replenishment of the chemistry used by the Avantara 20/25 OLP processor.

Using Plate Material

When you specify plate material as the imaging media, the SelectSet Avantra exposes areas outside the boundaries of the page defined by your front end application.

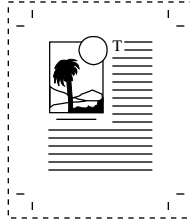

Figure C.1. This represents a page defined by your front end application. The dashed line represents the outside border of the page.

Figure C.2 on the next page shows different examples of how this feature works.

The depth of the top bar is calculated like this:

DEPTH = INTERPAGE SPACE + PUNCH REGION

PUNCH REGION = 0.8" (2 CM) IF ENABLED

PUNCH REGION = 0 IF DISABLED

For example:

INTERPAGE SPACE = 1" (2.5 CM)

PUNCH ENABLED = 0.8" (2 CM)

TOP BAR DEPTH = 1.8" (4.6 CM)

The top bar is imaged any time the top punch is enabled or the interpage space is greater than 0.

If you disable the punch and set the interpage space to 0, the top bar is not imaged. See E and F in Figure C.2.

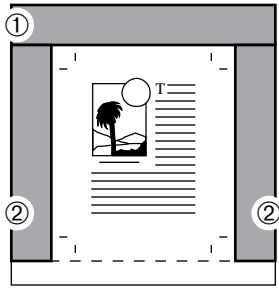

A.

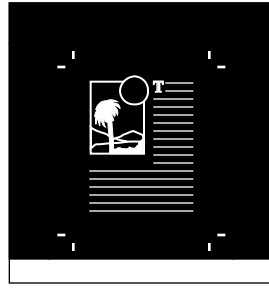

B.

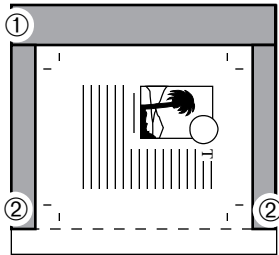

C.

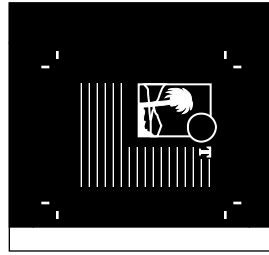

D.

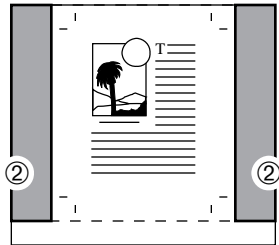

E.

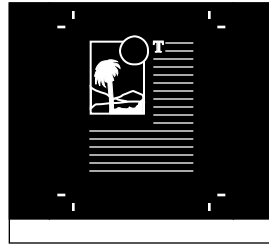

F.

Figure C.2 A, C, and E show the top bar (labeled ①) and side bars (labeled ②) that are exposed when plate is specified as the media.

B, D, and F represent the end result after the page is exposed and developed.

Note these tips when you use this feature:

- If a top bar is imaged, imaging time for a page is longer.
- If you need more exposed plate material, specify a larger page size through your front end application. See Figure C.3.
- Do not advance more than 90' (27.4 m) of Setprint HN LL 5 mil plate material into the take-up cassette.
- Do not advance more than 56' (17 m) of Setprint HN LL 8 mil plate material into the take-up cassette.
- Maximum image depth may be reduced. See Figure C.4. The gray bands show where the page may be clipped.

The top bar may overlap the top of your page by up to $\frac{1}{4}$ " (.7 cm).

If the page depth plus the top bar depth is greater than the drum length (22" or 55.8 cm), the top bar may overlap the bottom of the preceding page by up to $\frac{1}{4}$ " (.7 cm).

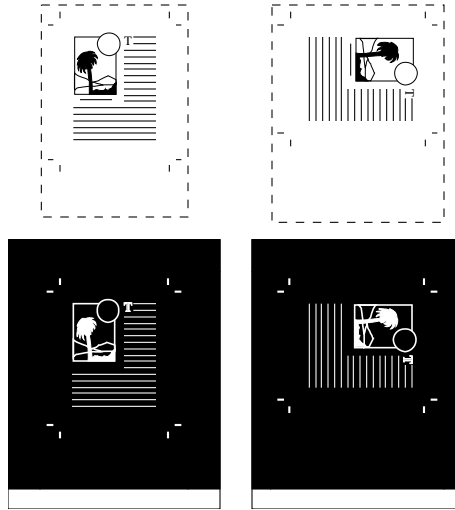

Figure C.3. Specify a larger page size in your page layout application to increase the exposed area around the page.

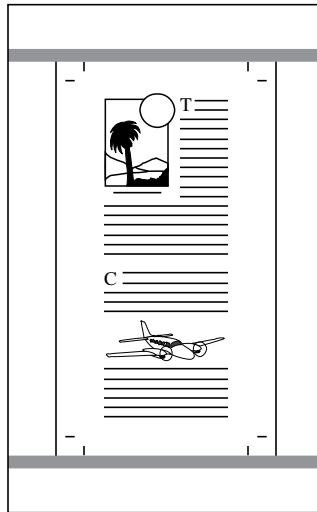

Figure C.4. Maximum page depth may be reduced.

Switching Media Supplies

The instructions for loading and unloading media supplies do not cover every possible situation. There may be occasions when you need to do something different. In these cases, you may need to use Switch Supplies button in the Utilities Screen. For example:

- Your imagesetter is equipped with the DualSupply Option. Two media supply cassettes are in place in the media supply compartment.
- Supply A is currently loaded, with media advanced into the drum. You want to remove Supply B and replace it with a different supply cassette.

Here is what you need to do:

Press Pause, then Unload.



This pulls the media from Supply A out of the drum and into the cassette so that it will not be fogged when you open the media supply compartment.

It also shifts the rollers that grip the media from Supply A so that they grip Supply B.

Press Utilities, then Switch Supplies.



This releases rollers that grip the leading edge of the media in Supply B. If you try to remove Supply B without doing this, media will be pulled out of the cassette.

At this point, open the external cover and light shield so that you can remove and replace the cassette in Supply B.

Press Pause, then Load.



When the media is loaded, you are ready to resume operation.

Processor Replenishment

Two kinds of replenishment automatically maintain the chemicals in the tanks at optimum quality:

1. Automatic replenishment to keep the concentration of developer and fixer at constant levels.
2. STDBY Replenishment.

In addition, the MAN REPL key allows you to replenish the chemicals manually.

Automatic Replenishment

Automatic replenishment compensates for chemical exhaustion in the following way:

The processor pumps 100 cc. of developer and fixer replenishment chemicals into the tanks according to a calculation based on the pre-set replenishment value, the area of the material, and the percentage density as set on the control panel.

When presetting replenishment values (cc. / square meter), you must refer to the information included on the material box and also the information provided by the chemical manufacturer. When the material is fed, the processor calculates its area (width x length).

STDBY Replenishment

STDBY replenishment is released at regular intervals to compensate for the evaporation and oxidation of developer and fixer. The replenishment takes place when the processor is in run mode (switched on), and in standby mode (switched off).

Because the amount of chemicals pumped into the tanks is always 100 cc., the interval between each pulse is automatically calculated as 100 cc. x 24 hours, and the result is divided by the preset value:

$$\text{Interval time} = \frac{100 \text{ cc.} \times 24 \text{ hours}^*}{\text{Preset Stdby Repl. Value}}$$

If the processor is on for periods of less than 24 hours, multiply the required Standby Repl. value by 24 hours and then divide the result by the number of working hours to obtain the new preset Standby Repl. value:

$$\text{Preset Stdby. Repl. Value} = \frac{\text{Required Stdby. Repl. Value} \times 24 \text{ Hours}}{\text{Working Hours}}$$

Manual Replenishment

Press the MAN REPL key to release replenisher manually. Each time you press the key, you release 100 cc. of developer and fixer. You may use this key to adjust the level of developer and fixer in the tanks, or to restore the balance or activity in the tanks in case of insufficient replenishment.

Minimum and Maximum Settings

Each processor function has a minimum and a maximum setting. They are:

Dev. time	10–60 seconds.
Dev./Fix Temp.	23–43° C.
Dryer Temp.	30–60° C.
Dev./Fix Repl.	10–999 ml.
Fix STDBY Repl.	0 - 2000 ml
Dev STDBY Repl.	0 - 2000 ml

Appendix C:
RIP User Tools

Introduction

This appendix describes the RIP user tools that are designed specifically for use with the SelectSet Avantra imagesetter. These tools come with your Agfa RIP.

The following topics are covered:

- A definition of RIP user tools.
- Guidelines for using tools.
- Descriptions of the tools, presented in charts.
- Information about media optimization and virtual cassette operation, two SelectSet Avantra features controlled only by RIP user tools.

RIP User Tools Defined

RIP user tools are files that contain instructions written in PostScript language. They provide an alternate method for controlling your SelectSet Avantra imagesetter. To pass these instructions to the imagesetter, you download them to your RIP.

For more information, refer to the documentation that comes with your Agfa RIP. These manuals describe procedures for downloading RIP user tools and they list other tools you can use with the SelectSet Avantra.

RIP Tools Match Control Panel Functions

RIP user tools enable you to change parameters and perform functions that are also controlled at the imagesetter control panel.

For example, the tools CENTDS and CENTEN perform the same function as the Autocentering button in the Configuration Screen. The same parameter can be changed from two different places. If one operator changes a parameter at the imagesetter and another operator changes the same parameter by downloading a tool, the output from your imagesetter could show unanticipated results.

Use RIP tools carefully. Remember that many control panel functions can also be performed by using RIP tools. Set up guidelines in your shop to ensure that, as operators change imagesetter parameters, everyone using the system is notified.

User Tools Charts

These charts list only the tools that are designed exclusively for use with SelectSet Avantra imagesetters. They are grouped according to the control panel screen that enables you to perform the same function.

There are additional tools, not listed in this appendix, that affect SelectSet Avantra imagesetters. For example, there are tools to change the imaging mode, imaging resolution, exposure settings, and more. For descriptions of these other tools, refer to your RIP documentation.

Pause

These tools perform functions found in the Pause Screen.

Filename	Description
LOADA	Loads spindle A.
LOADB	Loads spindle B.

Cassette Setup

These tools perform functions found in the Cassette Setup Screen.

Filename	Description
PNCHBOTH	Enables head and tail punches.
PNCHHEAD	Enables head punches only.
PNCHTAIL	Enables tail punches only.

Feed Amounts

These tools perform functions found in the Feed Amounts Screen.

Filename	Description
LDR-01	Subtracts 1 unit from the feed and cut value.
LDR-02	Subtracts 2 units from the feed and cut value.
LDR-05	Subtracts 5 units from the feed and cut value.
LDR-10	Subtracts 10 units from the feed and cut value.
LDR01	Adds 1 unit to the feed and cut value.
LDR02	Adds 2 units to the feed and cut value.
LDR05	Adds 5 units from the feed and cut value.
LDR10	Adds 10 units from the feed and cut value.
PGSPC-01	Subtracts 1 unit from interpage spacing.
PGSPC-02	Subtracts 2 units from interpage spacing.
PGSPC-05	Subtracts 5 units from interpage spacing.
PGSPC-10	Subtracts 10 units from interpage spacing.
PGSPC01	Adds 1 unit to interpage spacing .
PGSPC02	Adds 2 units to interpage spacing.
PGSPC05	Adds 5 units to interpage spacing.
PGSPC10	Adds 10 units to interpage spacing.

When you specify English units of measurement, these tools subtract inches. For example, LDR-10 would subtract 10" from the feed and cut value.

When you specify metric units of measurement, these tools subtract centimeters. For example, LDR-10 would subtract 10 cm from the feed and cut value.

Configuration

These tools perform functions found in the Configuration Screen.

Filename	Description
CENTDS	Disables auto-centering. Files are imaged flush with the left edge of the media.
CENTEN	Enables auto-centering. Files are imaged centered on the media.

Special Tools

These tools activate functions that you cannot access from the control panel. The only way to control these features is to download the appropriate tool.

Filename	Description
SET_M_O.OFF	Disables media optimization.
SET_M_O.ON	Enables media optimization.
SET_V_C.OFF	Disables virtual cassette.
SET_V_C.ON	Enables virtual cassette.

SelectSet Avantra Special Tools

These SelectSet Avantra features can be activated only by using software tools:

- Virtual cassette operation.
- Media optimization.

Virtual Cassette Operating Mode

SelectSet Avantra imagesetters equipped with both the DualSupply Option and an on-line processor and bridge can operate in *virtual cassette* mode.

Virtual cassette mode works like this:

- Specify on-line processor as the output mode in the Configuration Screen.
- Fill both media supply cassettes with the same media. (Same media type, width, thickness)
- In the Pause Screen, load one of the media supplies.
- Download the tool SET_V_C.ON to enable virtual cassette mode.
- Queue jobs to be imaged.
- Jobs are imaged until the current media supply sets off a low media alarm.
- The imagesetter completes the current job and sends it to the bridge. It then unloads the current supply and loads the other supply.
- Imaging continues until the second media supply sets off a low media alarm.
- The imagesetter remains in virtual cassette mode until you download the tool SET_V_C.OFF.

Media Optimization

When media optimization is active, the imagesetter compares the current media width and the dimensions of the next job to be imaged and rotates the image 90 degrees if that would use media more efficiently.

For example:

- Media optimization is active.
- The imagesetter is loaded with 12" (305 mm) media.
- The next job is 8" wide and 10" deep (203mm by 254 mm).
- The job is rotated 90 degrees when imaged.

Use SET_M_O.ON to enable media optimization. Use SET_M_O.OFF to disable the function.

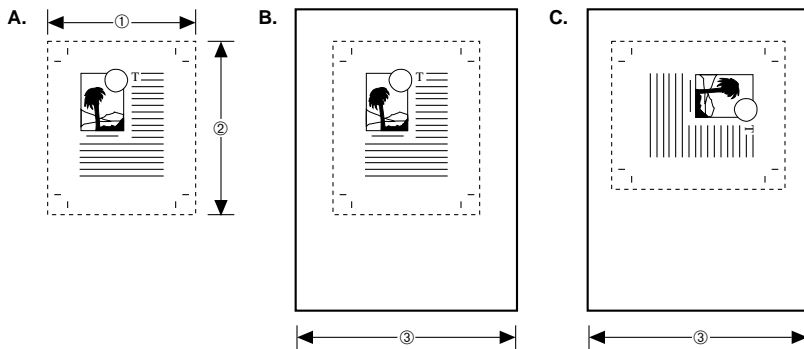

Figure B.1. Media optimization.

A. Hypothetical image. ①—Width, 8" (203 mm). ②—Depth, 10" (254 mm).

B. As imaged media with media optimization off. ③—12" (305 mm)

C. As imaged with optimization on. ③—12" (305 mm)

Index

4 dpi's test page, 5-4

A

Abort button, 2-6

Accept button, 2-6, 2-7

Alarms

supply, 3-14

take-up, 3-15

alignment mode, 3-9

Alignment, 3-9

Anti-oxidation, A-4

Assigning cassette numbers,
3-20

Auto on/off, 9-8

Autocentering, see alignment,
3-9

Automatic replenishment, B-8

Automatic functions, 9-5

Automatic start and stop, 9-5

Automatic start for processor,
9-2

Avantra 20/25 OLP, 1-6

B

Bar codes, 5-3

Boot Diagnostic Error, 6-5

Boot errors, 6-14

Bridge Communication Error,
6-10

Bridge Jam After Center Sensor,
6-11

Bridge Jam At Processor Entry,
6-11

Bridge Jam Before Center Sen-
sor, 6-10

Bridge Motor Jammed, 6-11

Bridge not in Position, 6-8

Bridge access panels, 8-8

Bridge media path, 6-12, 8-8

Bridge, 1-2, 8-2

Busy operating mode, 3-2

Button icons, 1-4, 2-3

Buttons, 1-4

- Abort, 2-6
- Accept, 2-6, 2-7
- and setting parameters, 2-9, 2-10
- Cancel, 2-6, 2-7
- Cut, 3-25
- Dial Out, 6-17
- Display Job History, 3-7
- Feed Amount, 3-23
- Feed and Cut Amount, 3-23
- Feed and Cut, 3-5
- Feed, 3-25
- Interpage Spacing, 3-23
- Load, 3-5
- Minus, 2-6, 2-7
- Minus, special features, 2-7
- Output Mode, 8-4
- Pause, 2-6
- Plus, 2-6, 2-7
- Plus, special features, 2-7
- Processor Timeout, 3-27
- Retract Punches and Nips, 3-25
- Reverse Feed, 3-25
- Run, 2-6
- Supply Alarm Amount, 3-23
- Switch Supplies, 3-25
- Take-up Alarm Amount, 3-23
- that change appearance, 2-11
- that you press twice, 2-11
- Unload, 3-6
- Viewing Angle, 3-27
- Volume, 3-27

C

- Cancel button, 2-6, 2-7
- Carriage Hit End of Travel, 6-4
- Carriage Jam, 6-3
- Carriage Position Error, 6-6
- Carriage Speed Error, 6-9
- Carriage Switch Broken, 6-5
- Cassette number, 3-10
- Cassette parameters table, 3-21
- Cassette parameters, 3-19
 - and loading media, 4-7
- Cassette Setup Screen, 3-16
- Centered alignment mode, 3-9
- Changing temperature, 9-13
- Changing developer time, 9-12
- Changing time setting, 9-7
- Changing replenishment rates, 9-14
- Class I laser device, 1-9
- Configuration Screen, 2-9, 3-26
 - and on-line processor, 8-4
- Control panel screen and Viewing Angle, 3-27
- Control panel screens, 2-4
- Control panel speaker, 3-27

Control panel
 imagesetter, 1-4, 2-3
 processor, 9-3
Current job information, 3-3
Cut button, 3-25
Cut Not Allowed, 6-9
Cutter in Media Path, 6-4
Cutter Jam, 6-3
Cutter, 1-2

D

Daily maintenance, 9-22
Densitometers
 reflection, 5-10
 transmission, 5-10
Density, A-2
Dev. Temp. Incor. message, 9-4
Developer temperature, 9-13,
 A-2
Developer time, 9-12
Development, A-3
Diagnostics, 6-18
 errors, 6-8
 software, 6-14
Dial Out button, 6-17

Display Job History button, 3-7
Distance to punches, 3-23
Dmax, A-2
Door Open message, 9-29
Drum Intake filter, 7-14
Dryer saver, 9-17
Dual media supply. *See* Dual-
 Supply Option
DualSupply Option, 1-6, B-6,
 C-6, 3-25
 and engine status display,
 3-12
 and loading supply cassettes,
 4-6

E

Electronics enclosure intake fil-
 ter, 7-14
Emulsion batches, 5-5
Endcaps for supply cassettes,
 4-2
Engine status icons, 3-11
Exhaustion, 9-15, A-4
Exit Jam message, 9-29
Exit jam, 6-13

Exposure settings, and test pages, 5-2
Exposure status display, 3-13
Exposure test pages. *See* test pages
Exposure tests, 3-18, A-1
Exposure, 3-13, 3-18, A-2, A-3, A-5

F

Fatal boot errors, 6-18
Feed Amount, 3-23
Feed Amounts screen, 3-22
Feed and Cut Amount button, 3-23
Feed and Cut Before Changing Supply, 6-9
Feed and Cut button, 3-5
Feed and Cut when using the on-line processor, 3-5
Feed button, 3-25
Feed Cut Amount, 3-6
File name display, 3-3
Film input left, 9-4

Film input right, 9-4
Filters, 7-14
FlexMedia, 1-6
Flush left alignment mode, 3-9
Focuser Jam, 6-7
Format size, 1-5
Front end computer, 1-8
Function keys, processor, 9-4

H

Hardware Error, 6-4, 6-6, 6-10

I

Idle operating mode
 imagesetter, 3-2
 processor, 9-4
Intake filters, 7-14
Imagesetter messages
 1 Carriage Jam, 6-3
 3 Cutter Jam, 6-3
 6 Media Jam, 6-4
 7 Output Side Punch Jam, 6-4
 8 Cutter in Media Path, 6-4
 11 Carriage Hit End of Travel, 6-4
 12 Hardware Error, 6-4
 13 Left Side Door Open, 6-4

Imagesetter messages, *continued*

- 14 RIP Data Error, 6-5
- 15 No RIP, 6-5
- 17 Spinner Speed Error, 6-5
- 22 Spot Aperture Jam, 6-5
- 23 Boot Diagnostic Error, 6-5
- 25 Carriage Switch Broken, 6-5
- 27 Processor Alarm Signal, 6-6
- 28 Hardware Error, 6-6
- 31 Input Side Punch Jam, 6-6
- 32 Carriage Position Error, 6-6
- 33 No Media Currently Loaded, 6-7
- 34 Media in Take-up Cassette, 6-7
- 36 Supply Cassette Jam, 6-7
- 37 Take-up Cassette Jam, 6-7
- 38 Focuser Jam, 6-7
- 39 Polarizer Error, 6-7
- 4 Out of Media, 6-3
- 40 Diagnostic Error, 6-8
- 41 Bridge not in Position, 6-8
- 42 Right Side Door Open, 6-8
- 43 Internal Error, 6-9
- 44 Cut Not Allowed, 6-9
- 45 Feed and Cut Before Changing Supply, 6-9
- 46 Laser Bad, 6-9
- 47 Carriage Speed Error, 6-9
- 48 Invalid Engine Configuration, 6-10
- 49 Hardware Error, 6-10

Imagesetter messages, *continued*

- 5 No Take-up Cassette, 6-3
- 50 Hardware Error, 6-10
- 51 Bridge Communication Error, 6-10
- 52 Bridge Jam Before Center Sensor, 6-10
- 53 Bridge Jam At Processor Entry, 6-11
- 54 Bridge Jam After Center Sensor, 6-11
- 55 Bridge Motor Jammed, 6-11
- 56 No Response, Bridge Entry Sensor, 6-11
- 57 Processor Error, 6-13
- 58 No Processor Communication, 6-13
- 59 Processor Top Door Open, 6-13
- 60 Processor Communication Error, 6-14

Imaging mode status icons, 3-10

Imaging mode, 2-9, 3-28

Imaging resolution, 3-13

Imaging system, 1-8

Input Jam message, 6-13, 9-19, 9-28

Input Side Punch Jam, 6-6

Internal Error, 6-9

Internal clock, 9-6
Internal modem, 6-17
Interpage Spacing button, 3-23
Interpage spacing, 3-23
Invalid Engine Configuration,
6-10

J

Job in Bridge message, 9-4, 9-28
Job in Proces message, 9-28
job counter, 3-13
Job status icons, 3-13
Jog function, 9-5

L

Laser Bad, 6-9
Left Side Door Open, 6-4
Liquid crystal display, 1-4
Load button, 3-5
Loading media, 4-2
Low Level, 9-4

M

Main power switch, 1-2
Maintenance
 exterior, 7-11
 intake filters, 7-14
 interior, 7-12
 processor, 9-23 to 9-27
 punch trays, 7-15
 supply cassettes, 7-12
 supply rollers, 7-13
 take-up cassettes, 7-12
MAN REPL, 9-17, B-8, B-9
MAN START, 9-17
Manual Start message, 9-29
Manual replenishment, 9-17,
B-8, B-9
Manual start for processor, 9-2,
9-17
Maximum image size, 1-5
Media transport bridge. *See*
 Bridge
Media in Take-up Cassette, 6-7
Media Jam, 6-4
Media compartment, 1-2, 6-3,
7-9

Media loading, 4-2
Media optimization, C-7
Media processor. See On-line processor
Media remaining amount, 4-7
Media status icons, 3-8
Media supply compartment, 7-13
Media transport bridge, 1-2, 1-6
Media type, 3-10
Minus button, 2-6, 2-7
Modem, 6-18
Monthly maintenance, 9-26
Motor Overload message, 6-13, 9-29

N

Negative imaging mode, 3-28
Nip drive assembly, 7-2
Nip rollers, 3-25
No Media Currently Loaded, 6-7
No Processor Communication, 6-13
No Response, Bridge Entry Sensor, 6-11

No RIP, 6-5
No Take-up Cassette, 6-3
Nonfatal boot errors, 6-18

O

On-line processor, 1-6, 8-2
 alarm signals, 9-4
 and engine status display, 3-11
 and exposure tests, 5-5
 and Feed and Cut amount, 3-5
 and test pages, 5-7
 control panel, 9-3
 function keys, 9-4
 idle state, 9-4
 maintenance, 9-23 to 9-27
 offline operation, 9-19
 programs, 9-20
 run state, 9-4
 speed, A-2
 time setting, 9-7

On/off selection, checking, 9-10

Operating modes, 3-2
 Busy, 3-2
 Idle, 3-2
 Pause Pending, 3-2, 3-3

Optimum exposure, A-3
 Optional equipment, 1-6
 Out of Media, 6-3
 Output mode and Feed and Cut amount, 3-5
 Output Mode button, 8-4
 Output Side Punch Jam, 6-4
 Output devices, 1-8
 Overexposure, A-3
 Oxidation, 9-15, A-4

P

Pan Light, 9-16
 Panel light, 9-16
 Pause button, 2-6
 Pause Pending operating mode, 3-2, 3-3
 Pause Screen, 2-2, 3-4
 Photographic principles, A-1
 Plate material, B-2
 Plus button, 2-6
 special features, 2-7

Polarizer Error, 6-7
 Positive imaging mode, 3-28
 PostScript, C-2
 preset values, 9-11
 Processor Alarm Signal, 6-6
 Processor Communication Error, 6-14
 Processor Error, 6-13
 Processor Timeout button, 3-27
 Processor Top Door Open, 6-13
 Processor. *See* On-line processor
 Processor messages, 9-28
 Door Open, 9-29
 Exit Jam, 9-29
 Input Jam, 9-28
 Job in Bridge, 9-28
 Job in Proces, 9-28
 Manual Start, 9-29
 Motor Overload, 9-29

Progress bar, 2-2
 and startup procedure, 2-2
 and running jobs, 3-2
 and test pages, 5-7

Punch mode status icons, 3-9
 Punch trays, 7-15

R

- Raster image processor, see RIPs
- Reference band, 5-2
- Reflection densitometer, 5-10
- Repl. Empty, 9-4
- Replenishment, 9-14, 9-18, A-4, B-8
 - settings, B-10
 - standby, 9-15, B-9
 - rates, changing, 9-14
- Reset procedure, 6-2
- Resolution, 3-13
- Retract Punches and Nips button, 3-25
- Reverse Feed button, 3-25
- Right Side Door Open, 6-8
- Right reading imaging mode, 3-28
- RIP Data Error, 6-5
- RIP user tools, 3-1, C-2
- RIPs
 - and startup procedure, 2-2
 - hardware, 1-8
 - software, 1-8
- Run button, 2-6
- Run Screen, 2-2, 3-2
- Run state, processor, 9-4

S

- Safety instructions, 1-11
- Screens
 - Cassette Setup, 3-16
 - Configuration, 3-26
 - Feed Amounts, 3-22
 - Pause, 2-2, 3-4
 - Run, 2-2, 3-2
 - Utilities, 3-24
- Setting on and off time, 9-9
- Setting exposure, 3-18
- Shut down procedure, 2-3
- Single media supply engine status display, 3-12
- Software tools, 3-1
- Spinner Speed Error, 6-5
- Spot Aperture Jam, 6-5
- Standby mode, and jog function, 9-5
- Standby replenishment, 9-15, B-9
- Startup procedure
 - imagesetter, 2-2
 - processor, 9-2
- Status icons, 2-3
 - engine, 3-11
 - job, 3-13
 - media, 3-8
 - punch mode, 3-9

STDBY, B-9

Supply Alarm Amount button,
3-23

Supply Cassette Jam, 6-7

Supply alarm amount, 3-23

Supply alarm, 3-14

Supply cassette, 1-2, 6-7
and virtual cassette mode, C-6
loading, 4-2
cleaning, 7-12
removing, 4-9

Supply rollers, 3-25, 7-13

Switch Supplies button, 3-25

System clock, 9-6
resetting, 9-7

T

Take-up Alarm Amount button,
3-23

Take-up Cassette Jam, 6-7

Take-up alarm amount, 3-23

Take-up alarm, 3-15

Take-up cassette, 1-2, 6-3, 6-7,
B-4
and engine status display,
3-11
cleaning, 7-12
inserting, 4-12
media slot, 4-13
removing, 4-11

Test pages, 5-2

bar code, 5-3
executing, 3-18
increment, 5-3
reference band, 5-2
running, 3-18

Transmission densitometer, 5-10

U

Underexposure, A-3

Unload button, 3-6

Upgrade option, 1-6

User tools, 3-1

Utilities Screen, 2-7, 3-24, B-6

V

Ventilation, 1-11, 7-14

Viewing Angle button, 3-27

Virtual cassette mode, C-6

Volume button, 3-27

W

Weekly maintenance, processor,
9-23

Wrong reading imaging mode,
3-28