

# CHALLENGE CHAMPION 305 PAPER CUTTER

## Instruction Manual



Provided By

**MyBinding**.com®  
*When Image Matters.*

Serial Numbers 07X1360 & Up

# OPERATOR'S MANUAL



The Challenge Machinery Company  
6125 Norton Center Drive  
Norton Shores, MI 49441-6081 USA

ChallengeMachinery.com

## ***CHAMPION 305*** ***PAPER CUTTING*** ***MACHINE*** ***Models X, XG, XT***

*Sold and Serviced by*



**F.254-I-O**

October 2007

*When Image Matters.*

# 1.0 Introduction

---

This manual is designed to help you get the most from your Challenge equipment. Keep this manual in a safe, convenient place for quick reference by operators and service personnel.

## **CAUTION**

**SAFETY ALERT!** This symbol means **CAUTION: Personal safety instructions!** Pay special attention to the instructions in bold type. Personal injury may result if the precautions are not read and followed.

**READ THIS MANUAL BEFORE OPERATING!** Follow the precautions and instructions given. If after reading the manual questions still remain, contact your Authorized Challenge Dealer.

**FOR PARTS AND SERVICE,** contact the Authorized Challenge Dealer from whom you purchased the machine. Use the illustrations and parts lists at the back of this manual to identify the correct parts needed. Always give the **SERIAL NUMBER** and **MODEL** of your machine to insure the correct parts are sent as soon as possible.

**RECORD YOUR MACHINE SERIAL NUMBER** in the space provided on the front cover of this manual. Fill out the warranty card accompanying your machine and return it **DIRECTLY TO CHALLENGE.**

If you bought a used machine, it is important to have the following information on record at Challenge. Copy this page, fill in the information and send it care of The Challenge Service Department, 6125 Norton Center Drive • Norton Shores • MI 49441.

CHALLENGE MODEL	SERIAL NUMBER	
ATTN	COMPANY	
ADDRESS		
CITY	STATE/PROVINCE	ZIP
PHONE	DATE INSTALLED	
DEALER NAME & CITY		

### \* WARRANTY INFORMATION \*

It is very important that you read and understand the conditions outlined in the *Warranty Information Sheet* attached to the outside of the shipping container of your machine.

The *Warranty Information Sheet* must be filled out completely and returned to THE CHALLENGE MACHINERY COMPANY in order for the warranty to be issued for this machine.

Challenge® is a registered trademark of  
The Challenge Machinery Company • 6125 Norton Center Drive • Norton Shores MI 49417  
Copyright© 1997-2009 by The Challenge Machinery Company. All rights reserved. Printed in the U.S.A

## TABLE OF CONTENTS

1.0 Introduction .....	2
2.0 Safety .....	6
2.1 Precautions .....	6
2.2 Power Lockout Procedure .....	6
2.3 Warning Label Definitions .....	7
3.0 Packing List .....	9
4.0 Specifications .....	10
5.0 Footprint .....	11
6.0 Installation & Setup .....	12
6.1 Inspecting Shipment .....	12
6.2 Uncrating .....	12
6.3 Lifting Instructions .....	12
6.4 Moving Instructions .....	13
6.5 Cleaning .....	13
6.6 Assembly .....	13
6.7 Hydraulic Power Unit Removal .....	13
6.8 Hydraulic Check .....	14
6.9 Power Hook-Up .....	15
6.9.1 Three Phase Hook-Up .....	15
6.9.2 Single Phase Hook-Up .....	16
7.0 Champion 305 Diagram .....	18
8.0 Operation X Model .....	19
8.1 Power – Main Switch .....	19
8.2 Table Light .....	20
8.3 Presetting the Backgauge .....	20
8.4 Backlash Indicator .....	20
8.5 Backgauge Lock .....	20
8.6 IN/MM Toggle Soft Key .....	20
8.7 Making a Cut .....	20
8.8 Turning Off the Hydraulic Motor .....	21
8.9 Jogging Aid .....	21
8.10 Pre-Clamping .....	21
8.11 Air Table ON/OFF .....	21
8.12 Adjusting the Clamp Pressure .....	22
8.13 Re-calibrating the Backgauge .....	22
8.14 Knife Down Mode .....	22
8.15 Electric Eyes .....	23
8.16 False Clamp Plate .....	23
9.0 Operation – XG Model .....	24
9.1 Using the Machine .....	24
9.1.1 Power - Main Power Switch .....	24
9.1.2 Table Light .....	24
9.1.3 Start Up .....	24
9.1.4 Making a Cut .....	25
9.1.5 Jogging Aid .....	25
9.1.6 Adjusting the Clamp Pressure .....	26
9.1.7 Pre-Clamping .....	26
9.1.8 Knife Change Alarm and Lubrication Alarm .....	26
9.2 Electric Eyes .....	26
9.3 False Clamp Plate .....	26
9.4 Champion XG – Display Panel .....	27
9.5 Definition of Keys .....	27

9.5.1 Backgauge Glide Control .....	27
9.5.2 IN/MM Key .....	27
9.5.3 Air Table ON/OFF Key .....	27
9.5.4 Send Key .....	27
9.5.5 Push-Out Key.....	28
9.5.6 Clear Key .....	28
9.5.7 Enter Key .....	28
9.5.8 Priority Add (X/Y) Key .....	28
9.5.9 Soft Keys.....	28
9.5.10 Arrow Keys.....	28
9.5.11 Contrast Control.....	29
9.6 Manual Backgauge Control.....	29
9.6.1 Backgauge Glide Control .....	29
9.6.2 Backgauge Control Knob .....	29
9.6.3 Backlash Indicator.....	29
9.7 Send Mode .....	29
9.7.1 Entering Math.....	30
9.7.2 Entering Fractions.....	30
9.8 Repeat Mode.....	30
9.9 Maintenance Mode.....	31
9.9.1 Language .....	31
9.9.2 Parameters .....	31
9.9.3 Diagnostic .....	32
9.10 Job Mode.....	33
9.10.1 Lock/Unlocking a Job.....	34
9.10.2 Copying a Job .....	34
9.10.3 Erasing a Job .....	34
9.10.4 Creating a New Job .....	34
9.10.5 Editing an Existing Job.....	38
9.10.6 Running a Programmed Job.....	39
9.10.7 Exiting a Job .....	39
9.11 An Example Job – XG Model .....	40
10.0 Operating Tips .....	41
11.0 Knife Installation/Changing.....	42
11.1 Knife Removal .....	43
11.2 Knife Installation .....	44
11.3 Using the Shielded Knife Lifter .....	45
11.4 False Clamp Plate .....	46
11.5 Knife Care Basics.....	47
11.5.1 Cut Quality .....	47
11.6 Bevel Angle .....	48
11.7 Helpful Suggestions .....	48
11.8 Knife Care .....	49
12.0 Lubrication .....	50
12.1 Hydraulic System .....	52
12.2 Recommended Oils.....	53
12.3 Changing the Oil.....	53
13.0 Operator Adjustments/Cleaning .....	55
13.1 Line Lights .....	55
13.2 Manual Pressure Reducer – (305X Only) .....	56
13.3 Operator Cleaning.....	57
13.3.1 Hydraulics .....	57
13.3.2 Table Conditioning .....	57
13.3.3 Console.....	58
13.3.4 Machine Base .....	58

14.0 Program Log .....59  
15.0 Channel Log.....60  
16.0 Safety System Tests .....61

# 2.0 Safety

---

## 2.1 Precautions

- This machine is designed for one-person operation. Never operate the machine with more than one person.
- Safe use of this machine is the responsibility of the operator. Use good judgment and common sense when working with and around this machine.
- Read and understand all instructions thoroughly before using the machine. If questions remain, contact the dealer from which you purchased this machine. Failure to understand the operating instructions may result in personal injury.
- Only trained and authorized people should operate this machine.
- Do not alter safety guards or devices. They are for your protection. Severe personal injury may result.
- Disconnect power before cleaning or performing maintenance. See Section 2.2 Power Lockout Procedure.
- Observe all caution labels and plates on this machine.
- Be sure the cutter is properly grounded.
- Be sure there is sufficient power to operate the cutter properly.
- Keep foreign objects off the table and away from cutter blade.
- **BE EXTREMELY CAREFUL** when handling and changing the cutter knife. Severe lacerations or dismemberment could result from careless handling procedures.
- Keep the floor around the cutter free of trim, debris, oil and grease.
- When replacing hydraulic parts, loosen the connections slowly to release pressure. Never loosen connections with the machine running.
- If the cutter sounds unusual or operates abnormally, turn it off and consult the troubleshooting section of this manual. If the problem cannot be corrected, have it checked by a qualified service person.
- **CRUSH HAZARD**, keep hands and fingers from under the clamp while clamping. Use Jogging Aid to load paper, and use the backgauge to push paper out before unloading. **DO NOT REACH UNDER THE KNIFE AND CLAMP AREA!**

## 2.2 Power Lockout Procedure

For maximum safety when making adjustments or repairs to your machine, be sure to lock out the main power control switch to which the machine is connected. The switch should be moved to the OFF position and a padlock placed in the loop. The person servicing the machine should hold the key.



Figure 1

## 2.3 Warning Label Definitions

The following warning labels are found at various locations on your machine. Read and understand the meaning of each symbol. If a label is lost from the machine, it should be replaced. The item number and location of each label can be found in Section 17.0, Schematics and Parts List.



### HAZARDOUS AREA

Disconnect power before cleaning, servicing, or making adjustments not requiring power. Do not alter safety guards or devices; they are for your protection. Replace all guards. Do not operate with any guards removed.



### SHOCK HAZARD

Disconnect power before removing cover. Replace cover before operation.



### SHOCK HAZARD

Disconnect power before removing cover. Replace cover before operation.



### SINGLE OPERATOR

Do not operate with more than one person.

# !OJO!

## **CAUTION**

This Este simbolo de alerta de seguridad significa ¡ OJO ! - INSTRUCCIONES DE SEGURIDAD PERSONAL. Lea las instrucciones porque se refieren a su seguridad personal. Fall de obedecer las instrucciones que siguen podria resultar en lesiones corporales.

- Esta maquina, junto con sus mecanismos de seguridad, esta disenada para ser manejada por
- **UNA SOLA PERSONA** a la vez. Jamas debe ser manejada por mas de una persona al mismo tiempo.
- La seguridad es la responsabilidad del operario que usa esta maquina.
- **LEA DETENIDAMENTE** el manual de instrucciones y las **PRECAUCIONES DE SEGURIDAD** antes de poner a funcionar la cortadora. Pidale a su supervisor una copia.
- El manejo de la guillotina debe estar exclusivamente a cargo de personal entrenado y autorizado para ello.
- **NO MODIFIQUE LOS MECANISMOS DE SEGURIDAD**, estan ahi para su proteccion no deben ni modificarse ni quitarse.
- **DESCONECTE LA CORRIENTE ELECTRICA** antes de proceder a hacerle servicio de limpieza, engrasar, o de hacer ajustes que no requieren corriente. Trabe el interruptor en la posicion **OFF** (apagado); vea "Procedimiento para cortar la corriente electrica" al pie de esta pagina.
- Eche llave a la guillotina y quite la llave cuando la maquina no esta en operacion; vea "Corriente electrica".
- Asegurese de que la guillotina este debidamente a tierra. Vea "Conexion de la fuerza electrica".
- Verifique el voltaje y asegurese de que este sea suficiente para el debido funcionamiento de la guillotina.
- Preste atencion a todas las placas con advertencias instaladas en esta guillotina.
- No permita que objetos estranos esten en la mesa o cerca de la cuchilla cortadora.
- **TENGA SUMO CUIDADO** al tocar y cambiar la cuchilla. Heridas severas y hasta desmembramiento pueden resultar del manejo sin cuidado o negligente.
- El suelo alrededor de la guillotina debe mantenerse despejado y libre de recortes, desperdicios, aceite y grasa.
- Al haber la necesidad de reemplazar partes hidraulicas, afloje todas las conexiones poco a poco para dejar escapar la presion. Jamas debe aflojarse conexiones mientras la maquina este andando.
- Si la guillotina empezara a sonar o trabajar diferentemente a lo acostumbrado, desconectela y consulte la seccion "Troubleshooting" (Reparador) de este manual. Si no es posible corregir el problema, llame a su servicio autorizado para que le examinen la maquina.
- **PELIGRO DE MACHUQUE** - Mantenga manos y dedos fuera de la agarradera mientras sujeta el papel. Use el calibrador trasero y su rueda de mano para empujar el papel cortado. **NO PONGA SUS MANOS BAJOLA CUCHILLA O AREA DE LA AGARRADERA.**
- **NO OPERE SIN LAS GUARDAS PROTECTORAS!**

## ¡ OJO ! PRECAUCION - **Como proceder para desconectar la corriente electrica.**

Para maxima seguridad durante ajustes y reparaciones de su maquina, verifique bien que el interruptor principal de control de corriente al cual la maquina esta conectada, este desconectado. El interruptor deba ser puesto en la posicion "OFF" (desconectado) y se debe poner un candado en la anilla. La llave del candado debe ser guardada por la persona que estara efectuando los trabajos de servicio o de reparacion en la guillotina.

Desconecte la corriente electrica antes de proceder a hacer cualquier ajuste o reparacion o de efectuar el engrase en cualquier maquina.

## 3.0 Packing List

Part No.	Description	Qty.
	Basic Machine	1
<b>Extension Side Tables:</b>		
47166	18 x 24 Steel Side Table	2
47164-1	Side Table Back Plate	2
H-6913-606	Side Table Bolts	8
H-6424-6	Side Table Hex Nuts	8
H-6939-616	Leveling Screws	4
H-6913-6008	Side Table Mounting Bolts (shipped installed)	4
H-7321-6	Side Table Mounting Washers (shipped installed)	4
47006-2	False Clamp Plate (shipped installed)	1
47507	Knife	2
H-6918-608	Knife Bolts	6
8815	Knife Washers, Special	6
4171	Cutting Sticks (one installed)	4
47575	Knife Lifter Assembly	1
A-12608-4	Jogging Aid	1
<b>Tool Kit:</b>		
5064	Cutting Stick Puller	1
W-164	Hex "T" Wrench	1
W-158	5/16 Open End Wrench	1
W-141	1/8"	1
W-137	5/32"	1
<b>Fuses:</b>		
E-2308	3.2 A (X, XG Series)	1
E-2330-7	5 A S.B. (X, XG Series)	1
E-889-35	1 A S.B. (X, XG Series)	1
E-889-5	4 A S.B. (X, XG Series)	1
E-889-9	8 A S.B. (X, XG Series)	1
E-2330-8	6.3 A S.B. (XG Series)	1
E-2330-3	2 A S.B. (XG Series)	1

## 4.0 Specifications

Description	Inch Units	Metric Units
Cutting Width	30 ½"	77.5 cm
Clamp Opening	4"	10.2 cm
Clamping Force	400-5000 lbs.	1.8 – 22 kN
Minimum Cut – Standard	¾"	1.9 cm
- Special	½"	1.3 cm
- w/ False Clamp Plate	2"	5.1 cm
Table Space		
Front: (std.)	25"	63.5 cm
Back:	30 ½"	77.5 cm
<b>Dimensions</b>		
Table Height	36 ½"	92.7 cm
Overall Height	58 ½"	148.6 cm
Overall Length	69 ½"	176.5 cm
Overall Width	48 ½"	123 cm
w/ Side Tables	78 ½"	200 cm
w/o Side Tables	48 ½"	123 cm
Approx. Net Weight	2550 lbs	1157 kg
Approx. Shipping Weight	2750 lbs	1247 kg
Will pass through door:		
Assembled	49"	125 cm
Table/treadle out	42"	112 cm
Table/treadle/pwr unit out	24-1/2"	63 cm
<b>Electrical</b>		
Standard: 5 HP, 3 Phase, 60 Hz AC; 208/230V, @ 25A or 460V @ 11.5A Optional: 5 HP, Single Phase, 60 Hz AC; 208V, @ 44A or 230V @ 44A 3 Phase, 50 Hz AC; 220V or 380V Single Phase, 50 Hz AC; 220V		
<b>Spacer</b>		
XD & XG series spacer has 9801 cuts on 99 channels. XT series spacer has 47000 cut positions within the machine. (Unlimited with USB Port.)  Minimum space between cut positions is 0.005" or 1mm. Repeat positioning accuracy is 0.003" or 0.05mm.		

### Electric Eyes –

Response time = 68 ms

Object detection capability = 12 mm

Challenge reserves the right to make changes to any product or specification without notice and without incurring responsibility to existing units.

# 5.0 Footprint

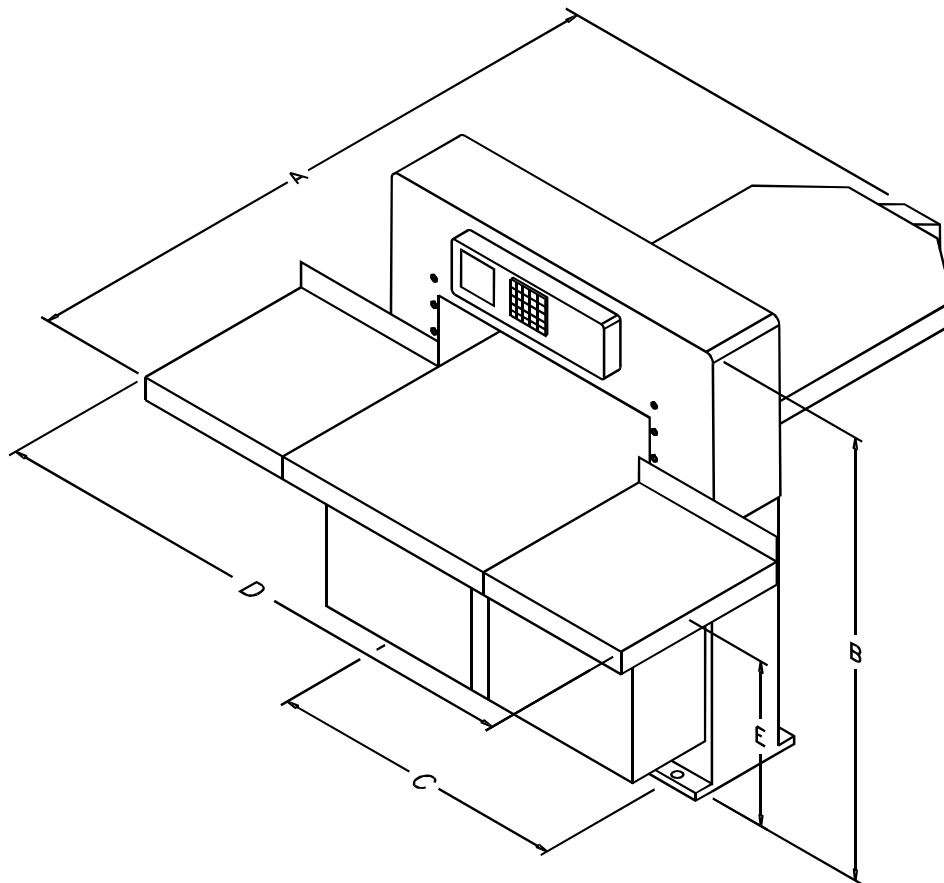

STANDARD SIDE TABLES

Symbol	Specification	CHAMPION 305		CHAMPION 370	
		Inch	cm	Inch	cm
A	Overall Length	69.5	176.5	86.25	219.1
B	Overall Height	58.5	149	60.0	152.4
C	Mounting-Front	41.5	105	60.25	153
D	Overall Width	78.5	200	109.0	276.9
E	Floor to Table	36.5	93	36.0	91.4
	Net Weight	2550lb	1159kg	3750lb	1701kg

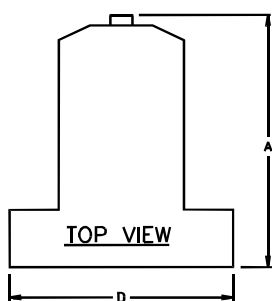

LARGE SIDE TABLES

Symbol	Specification	CHAMPION 305	
		Inch	cm
A	Overall Length	76.5	194.3
B	Overall Height	58.5	149
C	Mounting-Front	41.5	105
D	Overall Width	102.5	260.4
E	Floor to Table	36.5	93
	Net Weight	2600lb	1180kg

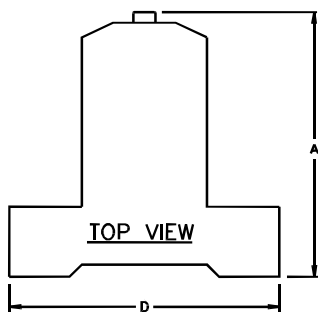

# 6.0 Installation & Setup

---

## 6.1 Inspecting Shipment

This machine has been carefully packed to prevent damage during shipment. However, claims for damage or loss are the responsibility of the recipient. Inspect all shipments as soon as they are received. If there is any noticeable damage, note it on the freight bill. Visual and/or hidden damage must be reported to the claims department of the carrier within 15 days. Contact your dealer if you need any assistance. Check the contents of the box against the packing list on page 9. Make sure there are no missing items.

## 6.2 Uncrating

This machine is lagged to a wood skid and covered with a triple-walled corrugated container. Loosen the flaps of the carton where they are attached to the skid. When loose, the carton can be lifted straight up. Remove the side tables and accessory box, which are also attached to the skid. Place the cutter/skid about where the machine will be positioned and remove the lag screws from the skid.

## 6.3 Lifting Instructions

Unpacking, handling, and positioning should be done by professional riggers. If handling or unpacking is a problem, your dealer or a local trucking facility should be able to supply or recommend a qualified rigger. This 2550-lb/1157-kg machine should be moved with experienced people and the proper equipment. Do not risk personal injury or damage by attempting to move machinery with inadequate equipment or manpower.

Champion cutters may include an optional block for lifting the machine. Remove the protective cover from the rear of the arch. Install the block with the hole up. Use a hook and chain or lifting straps rated at 3000-lb/1360-kg or higher. Carefully lift the machine off its skid, and remove the skid. Place the machine on the floor.

Lifting straps may also be used to lift the machine by placing the straps around the front and rear of the table. When straps are used in this way, wood blocks must be placed beside the lead screw to prevent damage, (Figure 2). A bent lead screw will cause the backgauge to bind.



**Figure 2**

The backgauge should be positioned all the way to the front of the table and straps placed as close the machine body as possible. Gently lift the cutter, remove the skid and carefully place the cutter on the floor.

Once the machine is off its skid, it can be moved with a forklift or pallet jack.

## 6.4 Moving Instructions

Use a forklift or pallet jack to move the machine from the front. Do not attempt to lift from the sides or rear.

## 6.5 Cleaning

Wipe down the table and bare metal surfaces with a non-flammable solvent such as CRC or blanket wash. The table surface is cast iron, and it will rust if left unprotected. Coat the table with a non-abrasive wax. A Cutter Care Kit, p/n 16077, with cleaner and wax, is available through your Authorized Challenge Dealer. The protective film on the console may be removed. **Never** clean console with petroleum based solvents. Damage will result. Also see, Operator Cleaning, pg. 57.

## 6.6 Assembly

Unless otherwise specified, the only items that have been disassembled for shipping are the knife and extension tables. Knife installation will be covered later. Extension table attachment follows.

**NOTE:** Extension tables are heavy. Use two people to attach them to the machine.

1. Assemble the back stops to the extension tables. The extension table bolts and hex nuts are packed in the tool kit box. Tables are installed with the clearance hole for the knife gibs towards the center of the cutter.
2. One person should hold the extension table in position while the other aligns the holes and starts threading the mounting bolts with washers. The mounting bolts are shipped installed in the side of table- remove them to install tables.
3. Use a 9/16" socket and extension to snug tighten the mounting bolts, then tap the extension table up or down with your hand or a rubber mallet until it is flush with the main table. Run a straight edge or sheet of paper over the seam to check the fit. Make sure your stock will not catch on the seam.
4. Insert the leveling setscrews into the threaded holes next to the mounting bolts. You may have to loosen the mounting bolts slightly to allow enough play to level the table. After the extension tables are leveled and the surface joints even, tighten the mounting bolts securely.
5. The extension tables are powder-coated and need only be wiped down with a dry cloth. DO NOT apply solvents or abrasive cleaners to extension table surfaces. They may cause discoloration or scratches.

## 6.7 Hydraulic Power Unit Removal

If installation requires that the machine pass through a doorway that is less than 49" but greater than or equal to 42" wide, the machine should have been ordered from Challenge "knocked down" with the table removed. If the machine must fit through a doorway that is less than 42" and greater than or equal to 24-1/2", the hydraulic power unit must be removed on-site. To remove the hydraulic power unit, follow the instructions below.

1. Disconnect the electrical conduits to the hydraulic motor, air blower, and hydraulic cooling fan, junction box.

2. Locate the hose that connects the manifold to the oil filter. Disconnect it from the filter. Disconnect the hydraulic pump hose from the manifold. Attach the hose that was connected to the manifold to the oil filter. Attach the hose that was connected to the filter to the manifold. This will minimize oil leakage. After the unit is installed, reconnect the hoses to their original location.
3. Remove the filler cap and use a transfer pump to remove the hydraulic fluid into buckets.
4. Remove the (4) bolts that attach the hydraulic assembly to the cutter base. They are located at the bottom shelf the base.
5. USE EXTREME CAUTION WHILE REMOVING THE POWER UNIT. It is very heavy and should be removed using a fork truck. CAUTION, the machine will be top heavy and may tip easily with the power unit removed. Move the reservoir through the doorway on its side.
6. DO NOT ATTEMPT TO LIFT THE CUTTER BY PLACING STRAPS OR THE FORKS OF A TRUCK UNDER THE CLAMP. This can damage the machine.
7. Reinstall the power unit, conduits, hoses, after the machine is in position. Refill the hydraulic reservoir.

## 6.8 Hydraulic Check

The hydraulic reservoir is filled with 13-1/2 gallons of ISO VG 46 hydraulic oil at the factory. The fluid level should be checked during installation, and at least once per week during normal operation. The reservoir is located behind the cutter, beneath the table (Figure 3). The hydraulic tank has a sight gauge in the rear for checking the oil level. The reservoir should be kept full at all times.

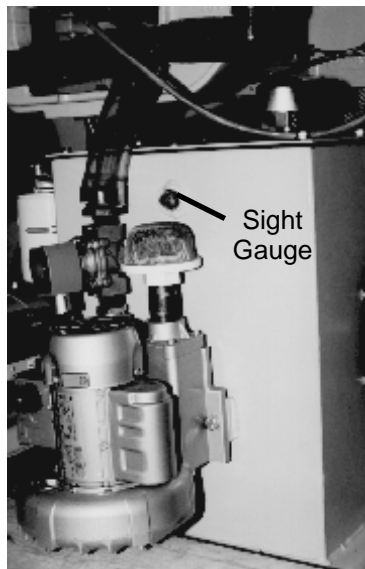

**Figure 3**

**NOTE:** DO NOT OVERFILL. Overfilling may cause leakage when the machine is hot.

## 6.9 Power Hook-Up

For satisfactory operation, be sure that your cutter is wired for the correct phase and voltage and has adequate power. The correct electrical specifications for your machine are shown on the serial plate. Check the machine serial plate before connecting the power. For future reference, transfer this information to the front cover of this manual.

**Watch Setup Voltage-** Inadequate power to the cutter can be a major source of problems. Too many machines on the same circuit will reduce the power to each machine. Inadequate voltage will cause overheating, loss of power, and in extreme cases, failure to operate. Test line voltage when the shop is at actual working levels. Challenge recommends a dedicated line with a lockable disconnect to provide adequate power for this machine.

**⚠ CAUTION** CAUTION: SHOCK HAZARD! Always disconnect power at main power panel before working on the cutter. Lock it out to prevent accidental power up. (See Power Lockout Procedure page 6).

**Important:** You must have an adequate size circuit and heavy enough wiring for this machine. The circuit size should be a minimum of 20% greater than the amperage rating on the machine nameplate. If a wire is run over 75 feet (23 meters), the next size wire should be used. Check local electrical codes.

### Electrical Specifications for Champion Cutters

	Volts	Amps	Circuit Size	Wire Size	Metric Wire
3 Phase:	460 V	11.5	20 A	#12 AWG	4mm sq.
	230	25	35	#8	10mm sq.
	208	25	35	#8	10mm sq.
1 Phase:	230	37	44	#6	16mm sq.
	208	38.7	44	#6	16mm sq.

### 6.9.1 Three Phase Hook-Up

The power source is connected to the cutter through the bottom of the power panel (right hand side).

1. **DISCONNECT AND LOCK OUT THE POWER** at the main panel to prevent accidental power up. (See Power Lockout, page 6).
2. Thread the power cord through a conduit connector into the power panel.
3. Fasten the ground lead to the ground terminal lug (Figure 4).

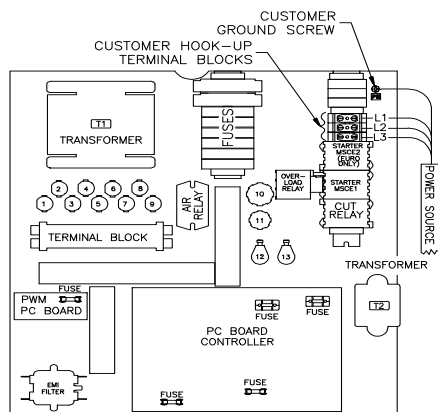

Figure 4

4. Fasten the three power leads to the three terminals of the main power terminal block- L1, L2, & L3.
5. Close the electrical panel doors and latch them. Unlock the main panel and turn on the power. Turn on the main power disconnect switch located on the front face of the table.
6. Press both cut buttons simultaneously to activate the motor and check to make sure it is turning the same direction as the arrow on the motor casing.

If it is not turning the proper direction, disconnect the power and exchange any two leads of the power cord as in Figure 5.

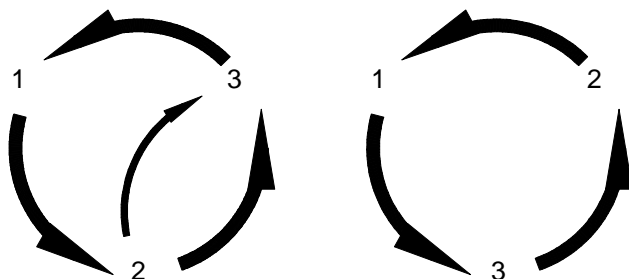

Figure 5

### 6.9.2 Single Phase Hook-Up

The power source is connected to the cutter through the bottom of the power panel (right hand side).

1. **DISCONNECT THE POWER AND LOCK IT OUT** at the main power panel to prevent accidental power up. (See Power Lockout, page 6).
2. Thread the power cord through a conduit connector into the power panel.
3. Fasten the ground lead to the ground terminal lug, (Figure 4 on page 16).
4. Fasten the two power leads to the L1 and L2 terminals of the main terminal block.

5. Close the electrical panel doors and latch them. Unlock the main panel and turn on the power. Turn on the main power disconnect switch and simultaneously press both cut buttons to start the hydraulic motor.

# 7.0 Champion 305 Diagram

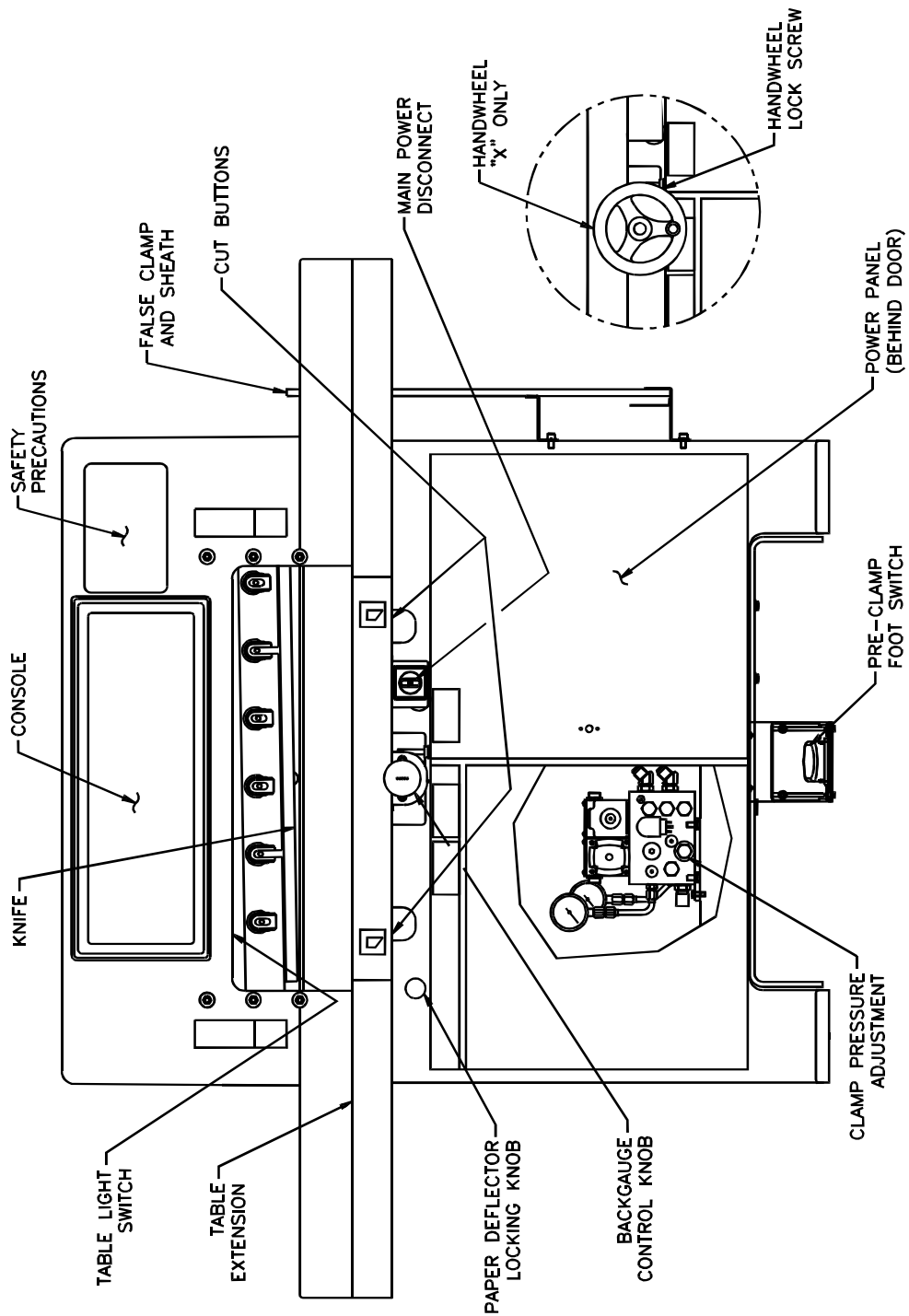
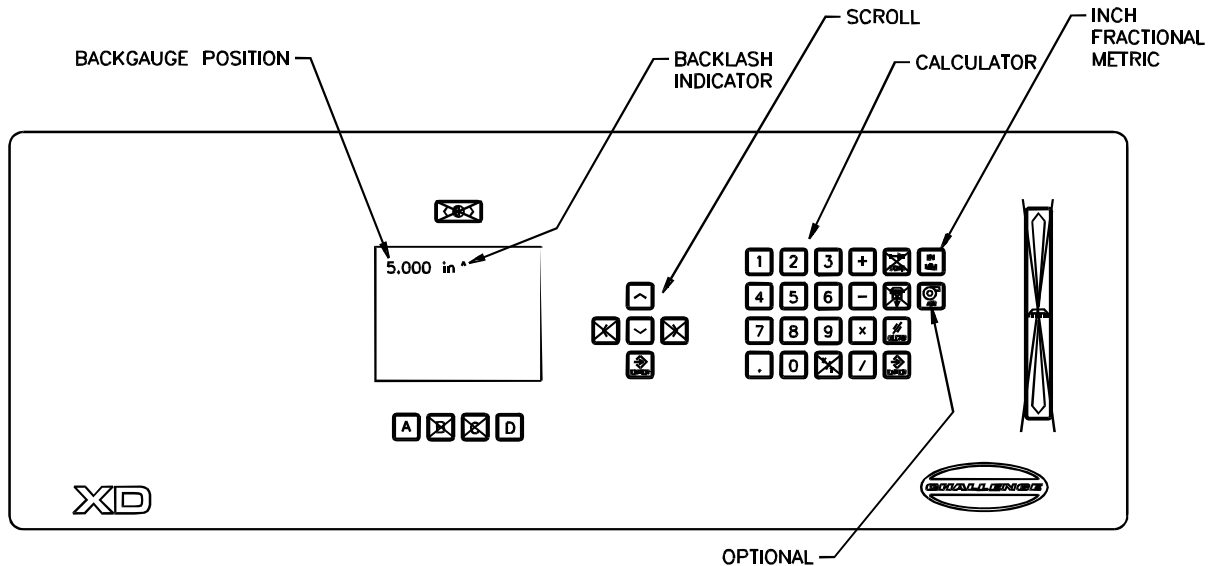

Figure 6

# 8.0 Operation X Model



NOTE: "X" THROUGH KEY INDICATES NON-FUNCTIONAL KEYS

Figure 7

IMPORTANT: DO NOT ATTEMPT TO OPERATE THE CUTTER UNTIL YOU HAVE THOROUGHLY READ AND UNDERSTAND ALL OF THE FOLLOWING INSTRUCTIONS. CALL YOUR AUTHORIZED CHALLENGE DEALER IF YOU STILL HAVE ANY QUESTIONS.

## 8.1 Power – Main Switch

Power is applied to the machine when the main power switch is turned to the "ON" position (Figure 8). The display and line lights are turned on at this time.

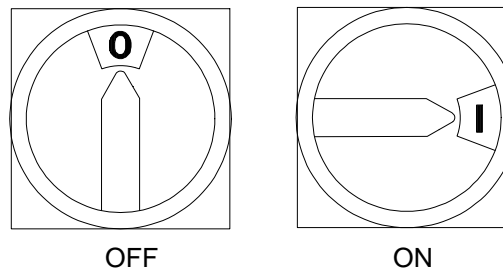

Figure 8

The display and line lights will shut off after 2 minutes without any activity. To restore power to the display and line lights, press either cut button.

## 8.2 Table Light

The table light is turned on and off using a switch located under the arch (Figure 6, page 18). The table light will also turn on and off with the main power, provided the table light switch is in the “on” position.

## 8.3 Presetting the Backgauge

The backgauge must be preset every time the power is turned on. Using the hand wheel, turn the backgauge until it passes forward through the 5” position. The display readout will then show the correct backgauge position.

## 8.4 Backlash Indicator

A small carat will be displayed next to the backgauge position if the backgauge was last moved backward. To insure accurate cuts, always approach the desired backgauge position from behind (moving the backgauge forward).

## 8.5 Backgauge Lock

Tightening the backgauge lock prevents the backgauge from moving while positioning paper against it. The Champion X model has a thumb screw lock beneath the hand wheel, (Figure 9).

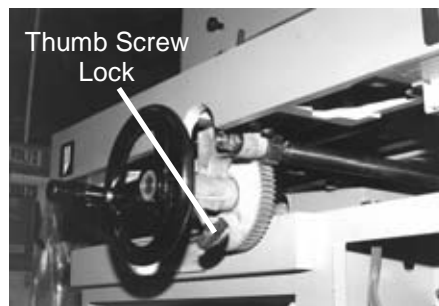

Figure 9

## 8.6 IN/MM Toggle Soft Key

This switch will toggle the display readout between inches, fractions, and millimeters. It can be found on the console as shown in Figure 7, on page 19.

## 8.7 Making a Cut

Place the paper against the backgauge and left side guide. Press and release both cut buttons once to start the hydraulic motor. Then press and hold both cut buttons to start the cut cycle. While holding the cut buttons, the knife and clamp will complete the cut cycle. If the buttons are released at any time during the cycle, the knife and clamp will immediately return to the up position.

Note: Both cut buttons must be released before a new cut can be made. The cut buttons must be pressed within 1/2 second of each other both to start the hydraulic motor and to make a cut.

**⚠ CAUTION**

DO NOT ATTEMPT TO REMOVE TRIM UNTIL THE KNIFE AND CLAMP HAVE STOPPED IN THE UP POSITION! Due to static buildup, fine trim may have a tendency to stick to the clamp or knife surfaces. Fingertips might be drawn into the knife by the clamp if this is attempted. Wait until the knife and clamp have BOTH STOPPED MOVING before removing stock trim.

## 8.8 Turning Off the Hydraulic Motor

The hydraulic motor will turn off after 2 minutes without any activity. The hydraulic motor can also be shut off manually by pressing and holding the left cut button.

## 8.9 Jogging Aid

All Champion cutters include a jogging aid as standard equipment. The jogging aid allows the operator to load and align stock without placing hands or arms under the clamp and knife area.

Load and align the paper against the side guide, (Figure 10), then square it to the backgauge for cutting.



Figure 10

Additional jogging aids can be purchased by contacting your authorized Challenge dealer.

**⚠ CAUTION**

Always remove the jogging aid from the table before making a cut.

## 8.10 Pre-Clamping

All Champion cutters are equipped with a low pressure clamping feature which allows the operator to clamp paper before beginning the cut cycle. To use this feature, press the footswitch until the clamp comes down on the paper. While holding the foot switch down, press the cut buttons. Release it once the cut has been completed. Although this is low pressure clamping, avoid placing hands under the clamp at all times.

## 8.11 Air Table ON/OFF

If your machine is equipped with an air table, it can be turned on and off by pressing the soft key shown in figure 7, page 19.

## 8.12 Adjusting the Clamp Pressure

**⚠ CAUTION** DO NOT set the clamp pressure below 300 psi. Pressures below this will not allow the auto-cycle to operate properly, and the knife will come down before the clamp. Severe lacerations and stock spoilage could result.

A pressure reducer valve and gauge located inside the left door housing on the front of the cutter below the table. By adjusting the pressure reducer valve, clamping pressure can be set (see Hydraulic Adjustments section) to a maximum of 1400 psi for heavy stock or large reams to a minimum of 300 psi for pressure sensitive jobs like carbon or NCR sets. For pressure sensitive stock using the false clamp plate is also recommended.

## 8.13 Re-calibrating the Backgauge

If the backgauge position readout does not match the actual measurement between the knife and the backgauge, the cutter must be re-calibrated. This inaccuracy can occur due to rough handling during shipment.

The accuracy can be checked by comparing cut sheets of paper. This process is described below.

**NOTE:** The backgauge gibs should be adjusted and the backgauge squared before attempting to re-zero, see Adjustments.

1. Place a 1/4 to 1/2 inch (5 to 13mm) pile of 8-1/2 X 11 (A4) paper against the center of the backgauge.
2. Trim cut lengthwise and rotate 180°. Using the backgauge position readout, bring the paper up to the 10" (254mm) position and make a cut. Move the backgauge up to 5" (127mm) and make another cut.
3. Take several sheets from the center of each lift and compare them to each other. The encoder system on your cutter will space accurately between your 10" (254mm) and 5" (127mm) cuts, whether the overall accuracy is correct or not. The stack of paper between the 10" (254mm) and 5" (127mm) cuts will be a true 5", but the paper left against the backgauge will not- if the backgauge position readout is off.
4. If the backgauge position readout is off, you will have to adjust the accuracy. This parameter provides a means for adjusting the accuracy of the backgauge. To change the accuracy, send the backgauge to 2 inches (50.8mm) and cut paper. Measure the paper, and type in what you actually measure. The computer will calculate the amount of error and will compensate. The amount of error could also be added to or subtracted from the value already displayed. Press "A" for Maint. Scroll to Parameters and Enter. Scroll to Accuracy Adjust and enter the measured value.
6. Run the backgauge back, then bring it forward through the 5" (127mm) pre-setter again and make another test.

## 8.14 Knife Down Mode

The knife down mode is used to send the knife and clamp to the down position without returning up. This provides a way for the service technician to change the knife. To send the knife down or up, enter maintenance mode, "A". Select either Knife Down or Knife Up, and then press the cut buttons. When sending the knife down, the cut buttons must be held until the motor stops.

## 8.15 Electric Eyes

The electric eyes prevent reaching into the cutting area while a cut is being made. If the beams are broken while a cut is being made, the knife and clamp will return to the up position.

## 8.16 False Clamp Plate

The false clamp plate should be stored in its sheath when not in use. The sheath contains a sensor that signals the computer that the false clamp plate has been removed. The computer automatically allows the minimum cut when the sensor detects the false clamp plate.

# 9.0 Operation – XG Model

IMPORTANT: DO NOT ATTEMPT TO OPERATE THE CUTTER UNTIL YOU HAVE THOROUGHLY READ AND UNDERSTAND ALL OF THE FOLLOWING INSTRUCTIONS. CALL YOUR AUTHORIZED CHALLENGE DEALER IF YOU STILL HAVE ANY QUESTIONS.

## 9.1 Using the Machine

### 9.1.1 Power - Main Power Switch

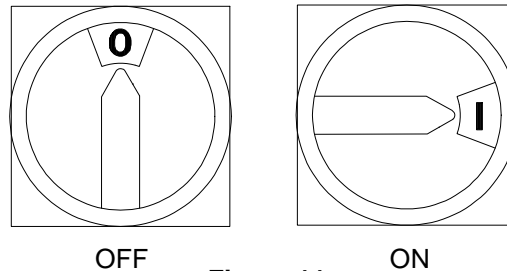

Figure 11

Power is brought to the machine when the main power switch is turned to the “ON” position (Figure 11). The display and line lights are turned on at this time.

The screen saver will activate and the line lights will shut off after 5 minutes without any activity. This shut-off time can be changed in the Parameters screen of the Maintenance Mode (see the “Operating Controls/Maintenance Mode/Parameters/Time Out” section). To restore power to the display and line lights, press any button on the keyboard.

### 9.1.2 Table Light

The table light is turned on and off by a switch located under the arch (Figure 6, on page 18). The table light will also turn on and off with the main power, provided the table light switch is in the “on” position.

### 9.1.3 Start Up

Once power has been turned on, the display will show the following:

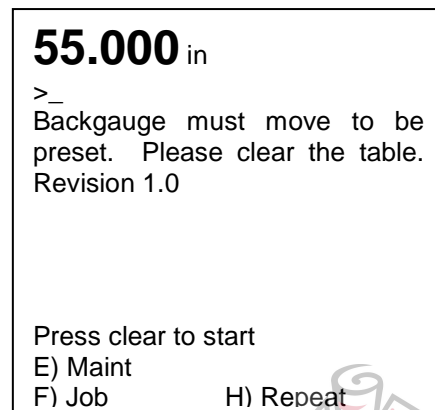
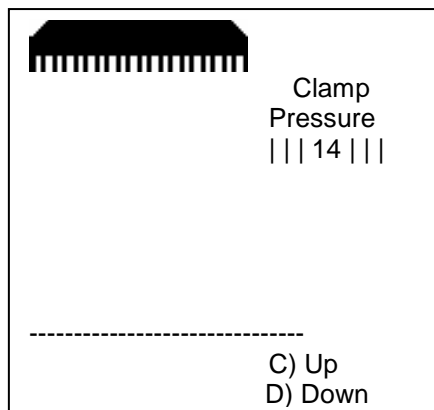

When the CLEAR key is pressed, the backgauge will move to coordinate the true position into the computer (if the knife and clamp are not in the “up” position, the display will prompt the operator to raise them by pressing the cut buttons prior to presetting the backgauge). When finished, the machine will be in “Send Mode” and the display will appear similar to the display shown below.

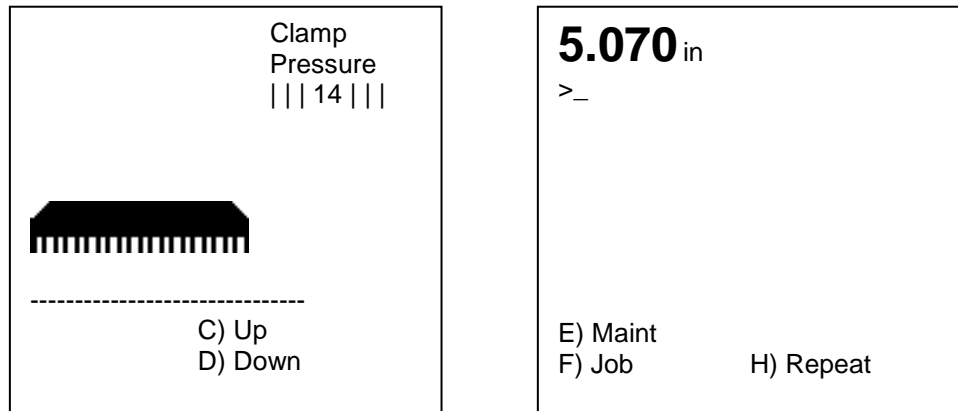

The backgauge may now be sent to a desired position by simply typing the dimension and pressing SEND (see the “Send Mode” section, page 29, for more details).

#### 9.1.4 Making a Cut

Place the paper against the backgauge and side guide. Press and release both cut buttons once to start the hydraulic motor. Then press and hold both cut buttons to start the cut cycle. While holding the cut buttons, the knife and clamp will complete the cut cycle. If the buttons are released at any time during the cycle, the knife and clamp will immediately return to the up position.

NOTE: Both cut buttons must be released before a new cut can be made. Also, the cut buttons must be pressed within 0.5 seconds of each other in order to make a cut.

**CAUTION** DO NOT ATTEMPT TO REMOVE TRIM UNTIL THE KNIFE AND CLAMP HAVE STOPPED IN THE UP POSITION! Due to static buildup, fine trim may have a tendency to stick to the clamp or knife surfaces. Fingertips might be drawn into the knife by the clamp if this is attempted. Wait until the knife and clamp have BOTH STOPPED MOVING before removing stock trim.

The hydraulic motor can be shut off at any time by pressing soft-key “B” (Mtr Off). The hydraulic motor will also shut off when the screen saver is activated. This shut-off time can be changed in the Parameters screen of the Maintenance Mode (see the “Operating Controls/Maintenance Mode/Parameters/Time Out” section, page 31).

#### 9.1.5 Jogging Aid

All Champion cutters include a jogging aid as standard equipment. The jogging aid allows the operator to load and align stock without placing hands or arms under the clamp and knife area.

Load and align the paper against the side guide, (Figure 12 on page 26), then square it to the backgauge for cutting.

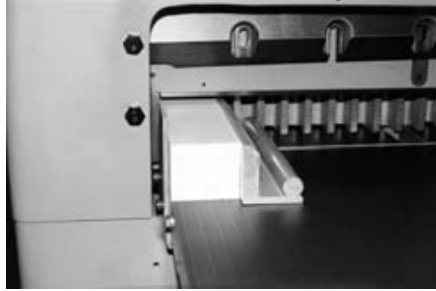

Figure 12

## **⚠ CAUTION**

Always remove the jogging aid from the table before making a cut.

Additional jogging aids can be purchased by contacting your authorized Challenge dealer.

### 9.1.6 Adjusting the Clamp Pressure

The clamp pressure can be adjusted by pressing soft-key “C” (Up) to increase the pressure, and soft-key “D” (Down) to decrease the pressure. The pressure scale ranges from 0 to 15, 15 being the maximum.

### 9.1.7 Pre-Clamping

All Champion cutters are equipped with a low pressure clamping feature which allows the operator to clamp paper before beginning the cut cycle. To use this feature, press the footswitch until the clamp comes down on the paper. While holding the foot switch down, press the cut buttons. Release it once the cut has been completed. Although this is low pressure clamping, avoid placing hands under the clamp.

### 9.1.8 Knife Change Alarm and Lubrication Alarm

The Champion 305 XG has two built in alarms that will be displayed after a certain number of cuts. The knife alarm displays a message to remind the operator to change the knife. The lube alarm displays a message to remind the operator to have the machine lubricated. The lube alarm will also display the name and phone number of the Challenge dealer from which the machine was purchased. To reset either alarm, or to change the knife alarm value, see the “Operating Controls/Maintenance Mode/Parameters/ Knife Count” section on page 32 . The lube alarm value is factory set at 2,500 cuts and cannot be changed.

## 9.2 Electric Eyes

The electric eyes prevent reaching into the cutting area while a cut is being made. If the beams are broken while a cut is being made, the knife and clamp will return to the up position.

## 9.3 False Clamp Plate

The false clamp plate should be stored in its sheath when not in use. The sheath contains a sensor that signals the computer that the false clamp plate has been removed. The computer automatically allows the minimum cut when the sensor detects the false clamp plate.

## 9.4 Champion XG – Display Panel

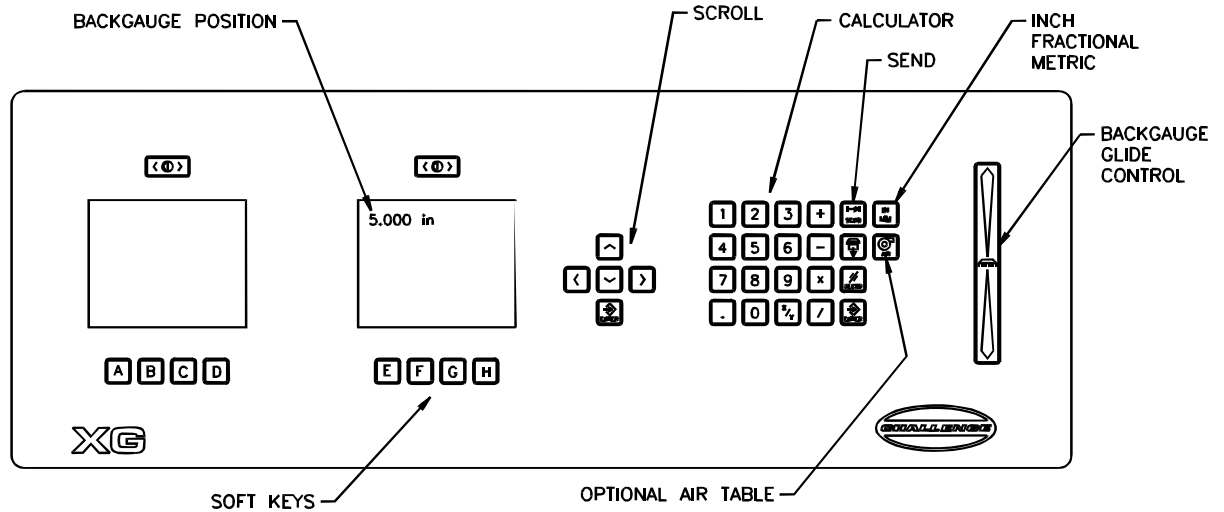

## 9.5 Definition of Keys

### 9.5.1 Backgauge Glide Control

The backgauge glide control is used to manually position the backgauge. The speed of the backgauge will depend upon where the actuator is pressed. Press farther from center for a faster speed, and closer to center for a slower speed. To move the backgauge forward, press downward. To move the backgauge backward, press upward.

### 9.5.2 IN/MM Key



This key toggles the display to show the position and programmed send values in inches (e.g. 5.250), inch fractions to the nearest 1/64" (e.g. 5\_1/4), or millimeters (e.g. 133.3).

### 9.5.3 Air Table ON/OFF Key



This key turns the air table on and off.

### 9.5.4 Send Key



The SEND key is used to send the backgauge to any valid position. If an attempt is made to send the backgauge to an illegal position, an error message will be displayed at the bottom of the screen stat-

ing “Number outside limit”. In the Job mode, the SEND key will also advance the backgauge to the next sequential cut position before performing the cut.

### 9.5.5 Push-Out Key



The push-out key will move the backgauge forward 5 inches (or to the most forward position) and then return it to its previous position. This allows paper to be removed from the cutter without putting hands under the knife and clamp.

**CAUTION** Never place hands in the clamp and knife area. Use the push-out key or the backgauge glide control to move the paper to an area where it can be reached.

### 9.5.6 Clear Key



The CLEAR key is used to clear error messages and the current entry line.

### 9.5.7 Enter Key



The ENTER key selects items in the maintenance mode and processes data that has been entered in the other modes.

### 9.5.8 Priority Add (X/Y) Key



The priority/add key is used for entering fractions when they are combined with whole numbers. The symbol displayed when this key is pressed is the underline symbol “\_”. An example of a number entered using the priority/add key is 1\_1/2.

### 9.5.9 Soft Keys

There are a total of eight Soft Keys labeled “A” through “H”. The functions of these keys change depending on the operating mode. The function of each key can be found on the bottom of the display screens.

### 9.5.10 Arrow Keys

The four arrow keys can be used in almost all screens. The arrow keys are primarily used for moving the cursor around on the screen, or to toggle between highlighted selections. In some screens, the left arrow key acts as a backspace key.

### 9.5.11 Contrast Control

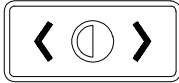

The contrast of each display screen can be adjusted by using the contrast control buttons located directly above each display screen.

## 9.6 Manual Backgauge Control

### 9.6.1 Backgauge Glide Control

The backgauge can be moved manually by use of the backgauge glide control. Press towards the operator for forward travel and away from the operator for reverse travel. The further away from center that the actuator is pushed, the faster the backgauge will travel. The backgauge moves faster, the more the knob is turned.

### 9.6.2 Backgauge Control Knob

The backgauge may also be controlled using the Backgauge Control Knob located at the front of the table. Turning the knob clockwise brings the backgauge forward. Turning the knob counter-clockwise sends the backgauge backward. The more the knob is turned, the faster the backgauge moves.

### 9.6.3 Backlash Indicator

To insure accurate cuts, the backgauge must be brought to the cut position from the rear of the table. In the display, to the right of the backgauge position, there is a small arrow to indicate reverse travel. This arrow should be off when making a cut. Moving back past your cut position, then forward to it, compensates for any play in the backgauge nut and lead screw.

## 9.7 Send Mode

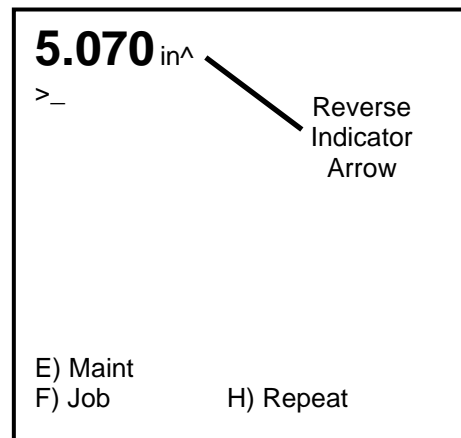
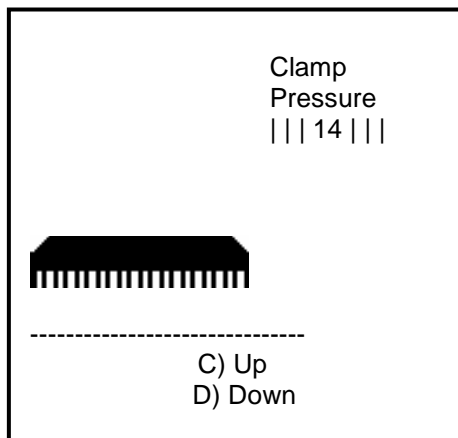

The send mode is the first screen displayed after the backgauge is preset. From this screen the backgauge can be positioned with the backgauge pinpoint control or by entering a value and pressing

the SEND key. A mathematical expression can also be entered as a send value. Simply type the expression and press SEND. You can also enter an equation which begins with the current back-gauge position. For example, if you want to send the backgauge 2" forward from its current position, just press [-] [2] and SEND.

The send mode screen can also be used for doing math calculations that are larger than the back-gauge's reverse limit. In this case, you must press ENTER to have the result displayed on the screen.

### 9.7.1 Entering Math

In the simple send mode, the Champion XG is capable of calculating an entire math string such as,  $10-5+5 \times 6+2 \frac{3}{4}$ . However, the result is limited to 29999.000 and the result cannot be a negative value. In the job mode, and during a send, the result of the calculation must be less than the back-gauge limit of 30.500 inches.

### 9.7.2 Entering Fractions

Fractions are entered with the priority add key X/Y. The symbol displayed when this key is pressed is the underline symbol "\_". This instructs the computer to add the fractional portion of the entry before performing the remaining math. This key is useful when entering a formula as follows:  $3 \times 2 \frac{3}{4} = 8 \frac{1}{4}$ . If a simple plus had been used instead, the result would be as follows:  $3 \times 2 + \frac{3}{4} = 6 \frac{3}{4}$ .

## 9.8 Repeat Mode

This mode allows the operator to make a series of cuts during which the backgauge moves a specified distance between each cut. To enter repeat mode, press soft-key "H" (Repeat). The display will then look like the one below:

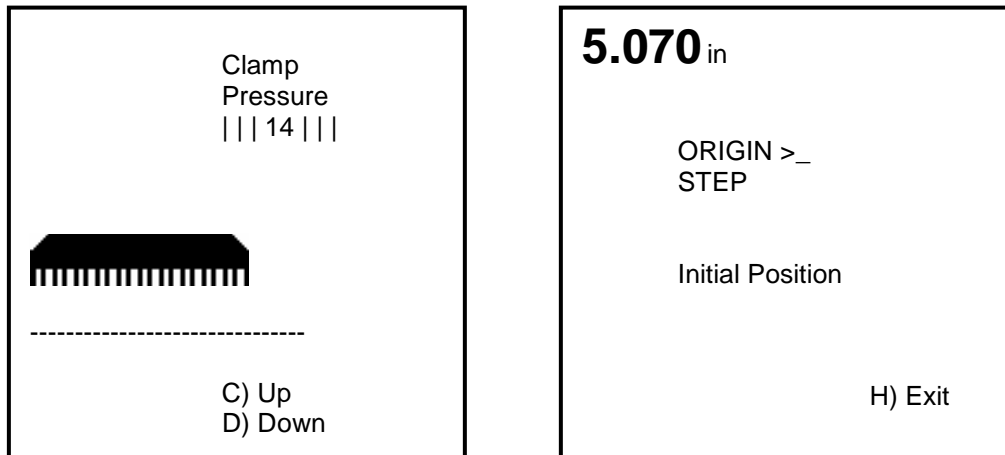

Type in the desired initial backgauge position and press ENTER. The backgauge will then move to that position. Then type in the step value and press ENTER. Position the paper and make a cut. The backgauge will then move forward by the step amount, and a new cut can be made. When finished, press soft-key "H" (Exit) to exit back to send mode.

## 9.9 Maintenance Mode

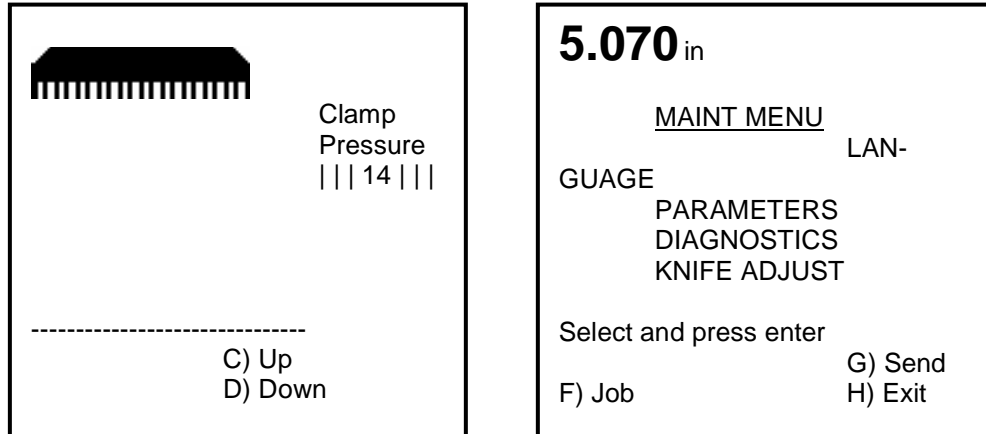

The maintenance mode is an area where many machine functions can be set or modified. The four principle functions are: Language, Parameters, Diagnostic, and Knife Adjust. To select a particular function, use the up and down arrow keys to toggle to the desired function and press ENTER. See the following descriptions for an explanation of each function.

### 9.9.1 Language

In the language screen, use the up and down arrow keys to toggle to the desired language, and press ENTER. All messages will be displayed in the selected language.

### 9.9.2 Parameters

In the parameter screen, use the up and down arrow keys to toggle to the desired parameter, and press ENTER. See the descriptions that follow for an explanation of each parameter.

#### 9.9.2.1 False Clamp

The false clamp plate is an optional attachment, which reduces the creasing of paper caused by the clamp. The disadvantage of using the false clamp plate is that it limits the smallest cut dimension. **The computer must know when the false clamp plate is installed on the machine to prevent the backgauge from crashing into it.** In the false clamp screen, use the up and down arrow keys to toggle between ON or OFF to indicate the presence of the false clamp plate, and press ENTER.

#### 9.9.2.2 Time-out

This parameter sets the amount of idle time for which the screen saver activates and the line lights and hydraulic motor turn off. The choices are 2, 5, 10, 20, and 30 minutes. In the time-out screen, use the up and down arrow keys to toggle to the desired time-out, and press ENTER.

#### 9.9.2.3 Push-out

Normally, whenever the backgauge is sent to a larger dimension, a five-inch (127mm) push-out is performed to aid the operator in accessing the paper. In some situations, it may be necessary to turn this feature off. It is recommended that this feature be left on whenever possible. In the push-out screen, use the up and down arrow keys to toggle to the on or off status as desired, and press ENTER.

#### 9.9.2.4 Accuracy Adjust

This parameter provides a means for adjusting the accuracy of the backgauge. To change the accuracy, send the backgauge to 2 inches (50.8mm) and cut some paper. Measure the paper, and type in what you actually measure. The computer will calculate the amount of error and will compensate. A value may also be added to or subtracted from the current value.

#### 9.9.2.5 Knife Count

The knife count parameter allows the operator to reset the knife alarm and the lube alarm. The knife alarm displays a message to remind the operator to change the knife. The lube alarm displays a message to remind the operator to have the machine lubricated. The lube alarm will also display the name and phone number of the Challenge dealer from which the machine was purchased.

There are three functions within the knife count parameter: Clear Count, Knife Alarm, and Clear Lube. Select the desired function and press ENTER. See the following descriptions for an explanation of each function.

Select **Clear count** to reset the knife counter when a knife change has been performed.

Select **Knife Alarm** to enter or change the knife stroke alarm value. When this value is reached, the display will alert you to change the knife and reset the knife counter. Knife alarm values for the Champion XG are factory set at 2,500 cuts. However, you may want to change this value based on your specific machine applications. See the Knife section for help in choosing a knife alarm value for your machine.

Select **Clear lube** to reset the lube alarm after performing the lubrication requirements as shown in the Lubrication section of this manual. NOTE: The alarm will activate after 2,500 cuts. This value is set at the factory and cannot be changed.

#### 9.9.2.6 Machine count

The number displayed is the total number of cuts made by the machine.

### 9.9.3 Diagnostic

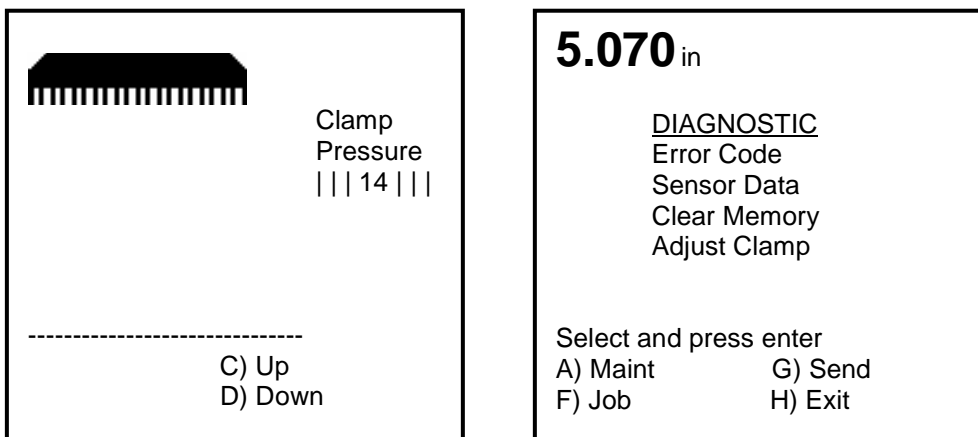

The diagnostic area can be very helpful in locating a problem in the event of a machine malfunction. Use the up and down arrow keys to toggle to the desired selection, and press ENTER. See the following descriptions for an explanation of each.

### 9.9.3.1 Error Code

The Error Code function simply recalls the last five error messages that were displayed. This can be very useful in cases when the malfunction cannot be reproduced in the presence of the service technician.

### 9.9.3.2 Sensor Data

The Sensor Data function provides a list of computer inputs and outputs (proximity switches, etc.) along with their status (0 for open, 1 for closed). This function allows a service technician to check the status of a switch without removing any covers. Cuts and backgauge movements are allowed in this screen so that the technician may observe the status of the inputs and outputs during machine operation.

### 9.9.3.3 Clear Memory

The Clear Memory function resets the memory to a known state. **All cut positions will be erased during this operation.**

### 9.9.3.4 Knife Adjust

The knife adjust function provides a way for the service technician to change the knife. In the Knife Adjust screen, use the up and down arrow keys to toggle to the up or down status as desired, and press ENTER. Press and hold the cut buttons to send the knife to the desired position.

## 9.10 Job Mode

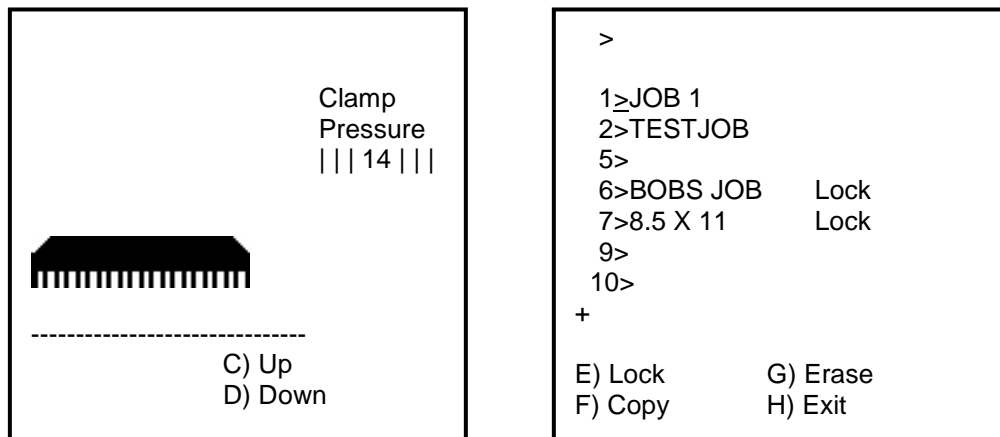

The Champion XG can be programmed for up to 99 different jobs. A job is a sequence of programmed cut positions. The backgauge moves to each position after a cut cycle is made. Each job can hold up to 99 send values. Job mode is entered by pressing soft-key "F". When the job mode is entered, all previously programmed jobs will be displayed along with their name and lock status. Locked jobs display the word "Lock" after their name. A plus "+" sign at the bottom of the screen indicates there are more jobs programmed than what are displayed. Pressing the left arrow key and the down arrow key simultaneously will page down to the next set of jobs. Page 59 contains an example of how to program a job.



gauge as a send value, 3) Use the “Cut and Record” feature (described later) or 4) Use the “Sheet Division” feature.

9.10.4.2 Creating a Stock Loading Position

After typing a send value, pressing the right arrow key instead of ENTER will move the cursor to the right and prompt the operator to enter a rotation indicator mark or Load Zone (LZ). Selecting LZ will make it impossible to cut at that position. Pressing both cut buttons on a position marked at a Loading Zone will prompt the backgauge to move to the next position in the job. Using a loading position eliminates the need to reach into the knife/clamp area of the cutter when loading a job.

9.10.4.3 Entering Rotation Mark

After typing in a send value, pressing the right arrow key instead of ENTER will move the cursor to the right and prompt the operator to enter a rotation indicator mark. The display will look similar to the one shown below:

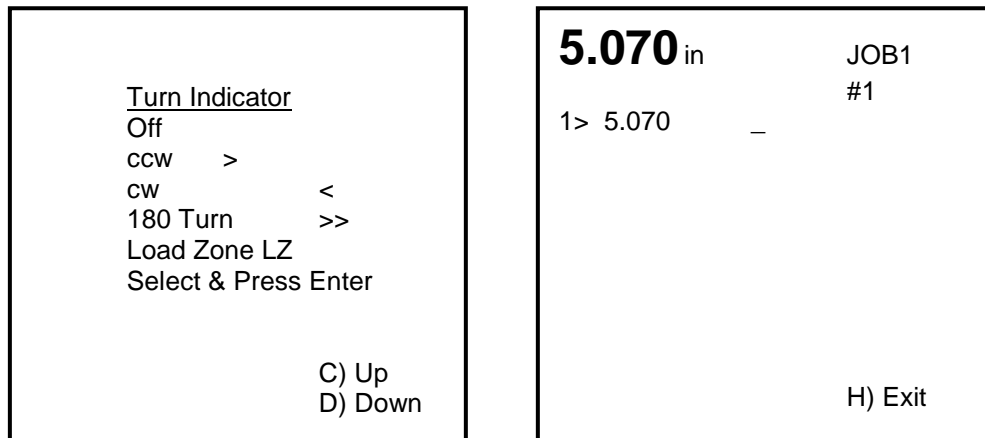

Use Soft Keys “C” and “D” to choose a turn indicator. Pressing ENTER will place an indicator mark to the right of the send value, as shown below:

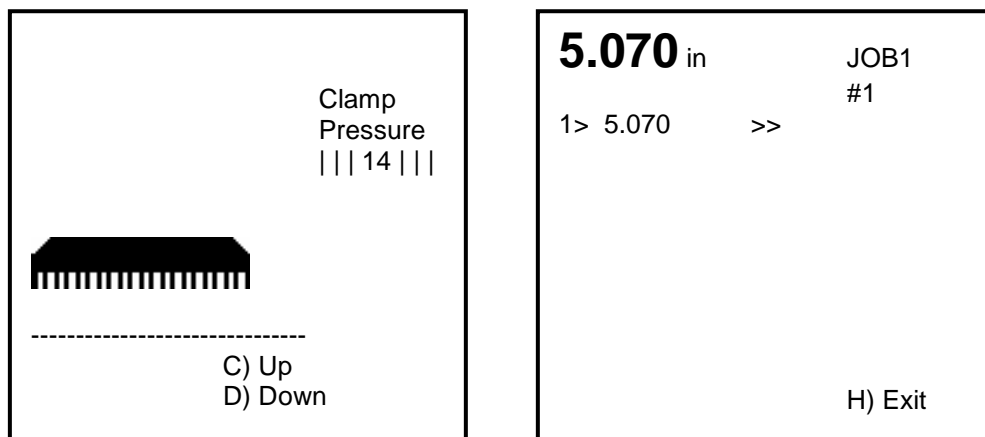

When the desired indicator mark is in place, press the right arrow key. The cursor will move to the right and prompt the operator to enter a clamp pressure (see the following section).

NOTE: All new entry lines will have the same turn indicator mark as the one above it, until it is changed.

#### 9.10.4.4 Entering the Clamp Pressure

A separate clamp pressure can be entered for each cut in a job. To enter the desired clamp pressure, first enter the desired send value (described above), then press the right arrow key and enter the rotation mark if necessary (described above), then press the right arrow key again to move the cursor to where the clamp pressure can be entered. Use Soft Keys "C" and "D" to increase or decrease the clamp pressure, or use the numeric keypad to enter a number from 0 to 15 (see Adjusting the Clamp Pressure section, page 26 for information about the clamp pressure setting). This will complete the entry for the current line and move the cursor to the send value of the next line.

NOTE: All new entry lines will have the same clamp pressure as the one above it, until it is changed.

#### 9.10.4.5 Cut and Record

To use this feature when creating a new job, simply send the backgauge to a desired position using the backgauge glide control or by using SEND, then make a cut. The current backgauge position will automatically be displayed in the next available cut location and the operator will be prompted to press ENTER to record the current value. If ENTER is not pressed, the value will not be recorded into the job as a send value. This can be very convenient for setting up a program when the actual cut positions are not known.

#### 9.10.4.6 Sheet Division Feature

The Champion XG has a sheet division feature that automatically creates a complete set of send values using the parent and finished sheet sizes specified by the user. Since this feature creates an entire set of send values, it is best to use it only when creating a new job. However, this feature can also be used when editing or using an existing job. It will simply insert the new set of send values after the current send value.

Begin by pressing soft-key "A" (Division). The display will be similar to the following:

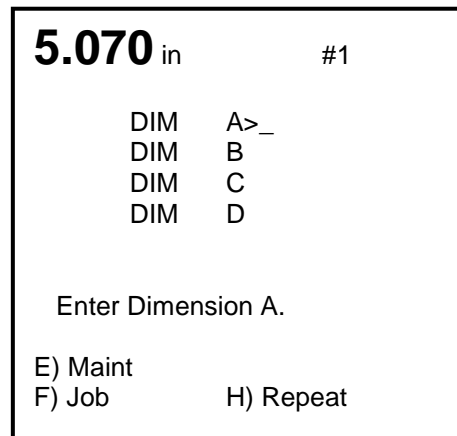
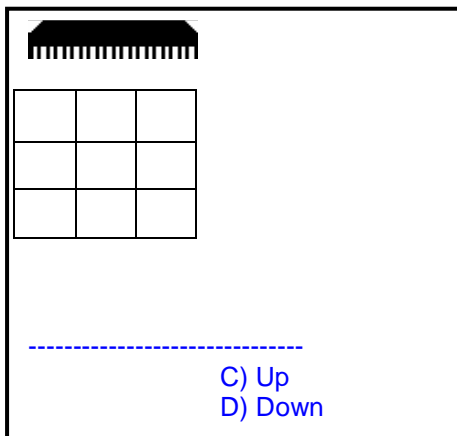

The program guides the operator through the steps of entering the necessary dimensions. Then the program asks if the columns are to be cut separate (as opposed to stacking the columns and cutting them all at once). Press "1" for Yes and "0" for No. The display will now look similar to the one shown on the next page (it may vary based on the input).

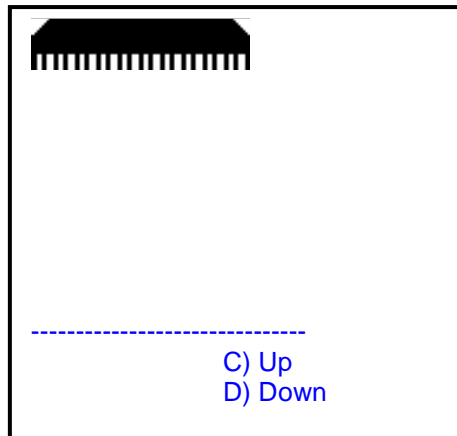

5.070		
OPT	QTY OUT	QTY CUTS
1	8	9
2	8	9
3	8	9
4	6	7
5	8	9
6	6	7
RE-ENTER		
		H) Exit

Use the up and down arrow keys to scroll through the possible layouts. The left display will show each choice visually. Select the desired option and press ENTER. The send values will be automatically calculated and entered. The job will be complete and ready for use. To make changes, edit the job as described in the “Editing a Job” section below.

#### 9.10.4.7 Label Cutting

A label cutting feature is also provided on the Champion XG. After providing the label quantity, size, and gutter, the machine will automatically create a programmed job. Begin by entering the job mode, select a job number and name (optional) then depress ENTER. Depress the soft-key “C” (Label) under the left hand display. The display will be similar to the following:

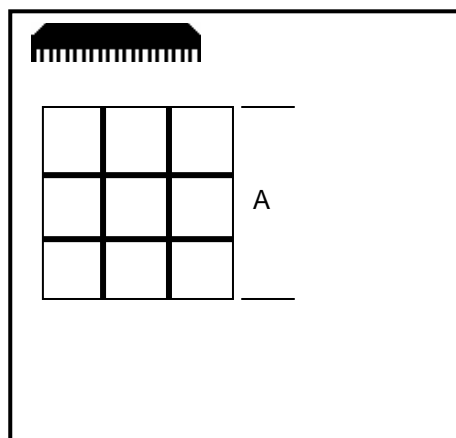

5.070 in		#1
*Label Cutting*		
QTY	A>_	
QTY	B_	
DIM	C	
DIM	D	
DIM	E	
DIM	F	
Enter Quantity A.		
E) Maint		
F) Job		H) Repeat

The program guides the operator through the steps of entering the necessary information. A & B are label quantities, C & D are the actual label size and E & F are gutter dimensions. Then the program asks if the columns are to be cut separate (as opposed to stacking the columns and cutting them all at once). Press “1” for Yes and “0” for No. The display will now look similar to the one shown on the next page (it will vary based on the input).

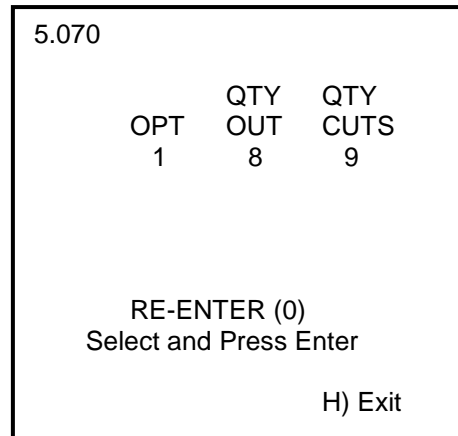
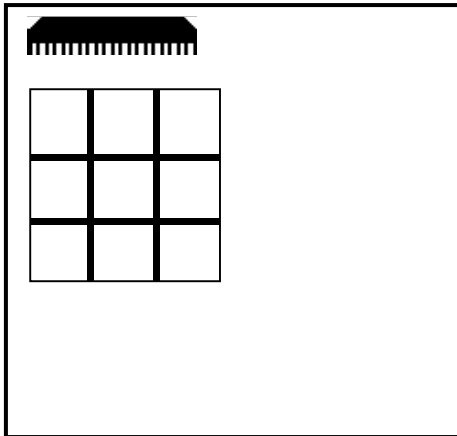

Use the up and down arrow keys to scroll through the possible options (if more than one). The left display will show each choice visually. Select the desired option, then press ENTER. At this point the send values will be automatically calculated and entered. The job will be complete and ready for use. To make changes, edit the job as described in the “Editing a Job” section below.

#### 9.10.4.8 When Finished

When finished entering send values you may exit the current job by pressing soft-key “B” (Job) to go back to the job mode screen or soft-key “D” (Exit) to exit to send mode. Or you may use the current job for cutting by pressing the down arrow at the last line and following the instructions in the “Running a Job” section (page 39).

### 9.10.5 Editing an Existing Job

#### 9.10.5.1 Editing the Job Name

The job name can be edited (or added if an existing job does not have a name) in the job mode screen. To edit the name, move the cursor down to the desired job number by pressing the down arrow key. Then press the right arrow key to move the cursor to the desired character position and edit the character by pressing the up or down arrow keys to toggle between characters of the alphabet. Numbers can be entered directly by using the number keys. Pressing CLEAR clears the current character. When finished, you may either go to the current job by pressing ENTER, or go to a different job, or exit job mode.

#### 9.10.5.2 Editing Send Values

To edit send values of an existing job, start by opening the desired job from the job mode screen. A job is opened by one of two methods: pointing at the desired job with the cursor and pressing ENTER, or by entering the job number with the keypad and pressing ENTER. Once a job has been opened, the current job number will be displayed in the upper right corner. NOTE: If the job is locked, it cannot be edited.

Send values can now be edited by moving the cursor up or down to the desired send value and then typing over the existing value. To page up and page down, press the left and down arrow keys simultaneously.

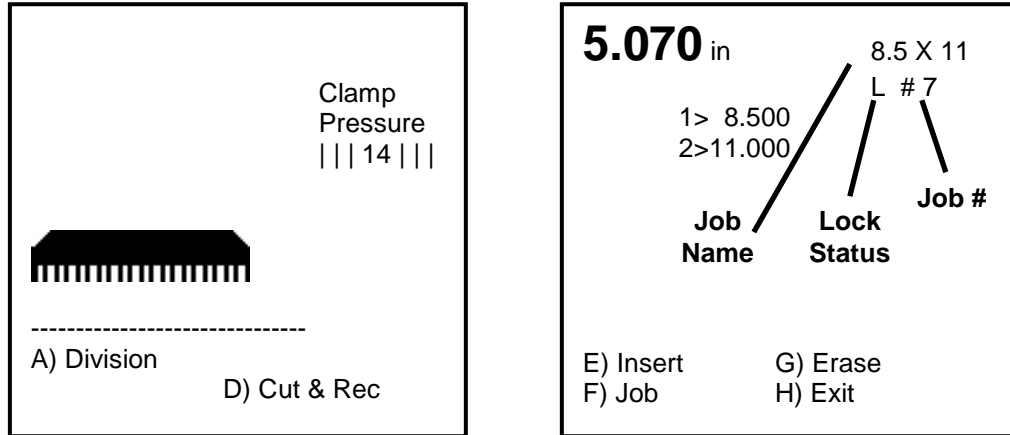

To insert a send value, press the soft-key “E” (Insert). This moves all send values down and provides a blank line after the current send value.

Send values can also be entered using the “Cut and Record” feature. Move the cursor to the line where the send values are to be inserted. Then press soft-key “D” (Cut & Rec). “C & R” will appear in the upper right corner of the left display. Each cut will add the current backgauge position as a send value. When finished, press soft-key “D” (Cut & Rec) again to exit cut & record mode. If there is a blank line where the cursor is, press the down arrow and it will disappear.

To erase a send value, press the soft-key “G” (Erase). This will remove the cut value currently being pointed to by the cursor. To backspace over the current send value without removing the line, press the left arrow key.

When finished editing the job, you may exit the current job by pressing soft-key “F” (Job) to go back to the job mode screen or soft-key “H” (Exit) to exit to send mode. Or you may use the job for cutting since it is already open.

### 9.10.6 Running a Programmed Job

To use an existing job for cutting, you must first open it by using one of two methods: move the cursor to the desired job with the arrow keys and press ENTER, or enter the job number with the keypad and press ENTER. Once a job has been opened, the current job name and number will be displayed in the upper right corner. Now press SEND to move the backgauge to the first programmed position (or send value). Make a cut by pressing both cut buttons. Once the cut is made, the backgauge will automatically push out the paper (only if the next position is larger than the current one, and if “push-out” is enabled) and move to the next programmed position. If the job was created using the “Sheet Division” feature, the left screen will display a diagram of where to place the paper for each cut. After the last cut in the job is made, the backgauge will move to the first cut position of the current job. Pressing SEND at any time during the job will send the backgauge to its next programmed position without making a cut. A plus “+” sign will be displayed at the bottom of the screen if more cuts remain in the current job.

### 9.10.7 Exiting a Job

To exit an open job, press the soft-key “F” (Job) to return to the job mode screen, or press the soft-key “H” (Exit) to exit to the send mode screen.

## 9.11 An Example Job – XG Model

The following is an example of how to program a job that will be used to make two cuts: one at 8.5” and one at 11”.

1. Turn on the machine and press CLEAR to preset the backgauge. Press the soft-key “F” (Job) to go to job mode.
2. Type in an unused job number and press ENTER. Note: It must be a number that does not correspond to an existing job. All existing jobs will be displayed on the screen (you may have to scroll through them to see them all). If you wish to replace an existing job with the new job, first erase the existing job by moving the cursor to it and press the soft-key “G” (Erase). Now type in the new number and press ENTER. In this example, job #'s 1, 2, 5, and 6 already exist. We will use job # 7 for our new job. Press “7” and ENTER.
3. The cursor will move down to the new job number. At this point, press the right arrow key once to move the cursor to the first character position. Now name the job “8.5 X 11”. To do this, press “8” on the number keypad. Then press the decimal “.” key and so on. To enter the spaces and the letter “X”, use the up and down arrow keys to toggle through the alphabet and press the right arrow key to move to the next character position.

Now press ENTER to begin programming the job.

4. To enter the first send value of 8.5”, simply type in 8.5 and press ENTER. The cursor will move to the second line. Now type 11 and press enter. At this point, you could exit and save the job by pressing the soft-key “H” (Exit) to exit to send mode, or the soft-key “F” (Job) to exit back to the job mode screen. However, lets use this job to cut paper.
5. Press the down arrow key once. This will remove the blank line 3 and move the cursor to the first send value (8.5”). Now press SEND. The backgauge will move to the 8.5” position. Place the paper to be cut against the backgauge and press the cut buttons. Once the cut cycle is complete, the backgauge will push out the paper and move to the next send value (11”). Now position the paper again and make another cut. After the cut is made, the backgauge will push out the stock and return to the first cut position, ready to repeat the current job.
6. Now lets lock the current job so it cannot be edited. First, exit back to job mode by pressing soft-key “F” (Job). Now move the cursor down to the new job using the down arrow key. Now press the soft-key “E” (Lock) to lock the job. A lock symbol will appear indicating the job has been locked.
7. To exit back to send mode, press the soft-key “H” (Exit).

---

## 10.0 Operating Tips

---

- Use a jogging aid to align stock. This will reduce the chance of an accident by not having to reach under the knife or clamp. Likewise, use the backgauge to push out stock before removal.
- Never attempt to remove paper trim clinging to the blade or clamp until they have stopped moving!
- Carefully lay out each sheet before you start cutting. Find the best-cut pattern to give you the most pieces out of the sheet. If the sheet will be folded, be sure the grain of the paper is running in the same direction as the fold or you will get a rough edge on the fold.
- If an accurate cut is necessary for close register work, you **MUST** have a sharp blade in the cutter. A dull blade will pull or draw the stock and cause uneven cutting. See Knives section, below.
- Clamp pressure should not be increased to eliminate draw without first checking for knife sharpness. Draw from a dull knife can only be eliminated by installing a sharp knife. See Knives section, below.
- Appropriate clamp pressure will vary from one stock to another. As a rule, you should have enough pressure to securely hold the stock but not so much that the stock is unacceptably deformed. Excessive clamp pressure causes pile distortion and inaccurate cutting.
- To make stock slide as easily as possible on the cutter table, wash the table with non-offset powder or with a silicone/rust preventative.
- Mark the gripper edge and the guide edge of printed stock and make sure the first cuts are with these guide edges against the backgauge.
- Measure printed stock to check for shrinkage or expansion of the paper from humidity. You may have to disregard the printed cut lines and make your own.
- If you notice the knife and clamp returning before the cut is complete, then the electric eyes are probably being triggered accidentally. A tie or loose clothing may cause this to occur.

# 11.0 Knife Installation/Changing

## **⚠ CAUTION**

Changing knives can be very dangerous unless safety precautions are observed and extreme care is taken when handling knives.

- Make sure knife lifters are properly installed, see instructions following.
- Keep handling of unprotected knives to an absolute minimum.
- Clear off cutter table before removing knife.
- Have scabbard on cutter table and insert knife immediately.
- Warn people of any unprotected knife.
- Knife changing is a **ONE PERSON OPERATION**. Having more than one person trying to change knives invites accidents.

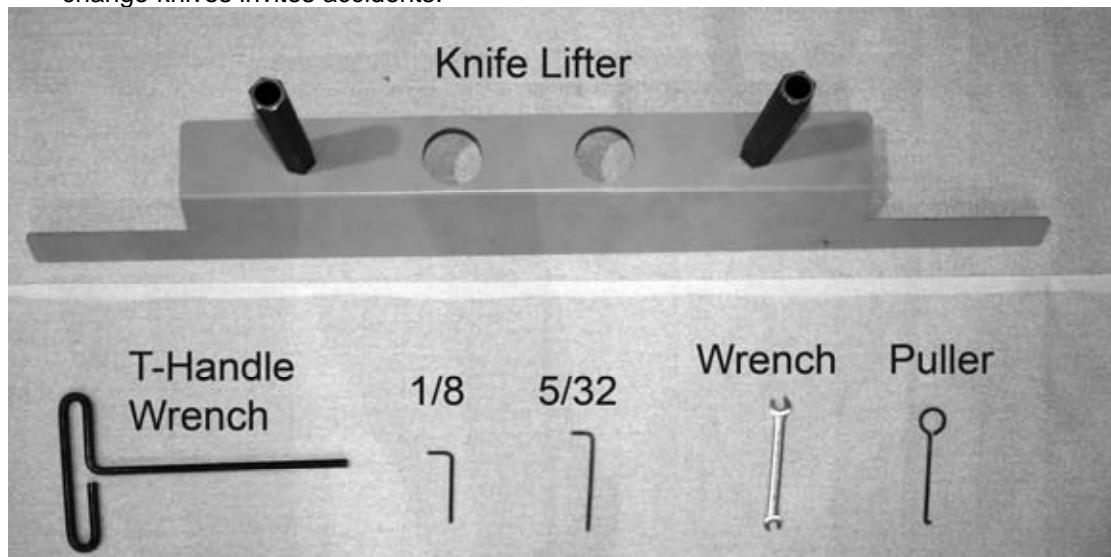

Figure 13 – Knife Changing Equipment

The knife changing equipment shown in Figure 13 is included in the cutter tool kit. The following instructions show how to remove and install a new or re-sharpened knife. Read these instructions AT LEAST ONCE before attempting to actually change or install any blades.

If your machine is serial no.99X524 or above you will have a shielded knife lifter instead of the loose knife lifters. The shielded knife lifter is shown in Figure 14. Before proceeding, read the special instructions for its use on page 46, Figure 20.

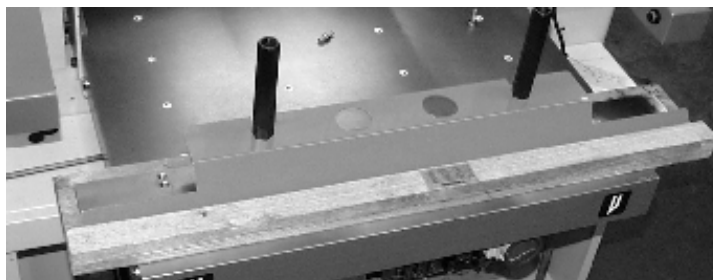

Figure 14

## 11.1 Knife Removal

1. Clear the cutter table. Place chipboard directly under the knife to prevent nicking if the blade hits the table.

**X, XG models)** On the screen menu choose "MAINT.," then "Knife Adjust" and then knife down. Press the cut buttons to send the knife down (in the knife down mode – hold the buttons until the hydraulic motor turns off). Then lock out the main power source as shown on page 6.

2. If equipped with the paper deflector option, lock it down by screwing the lock knob all the way in Figure 15.

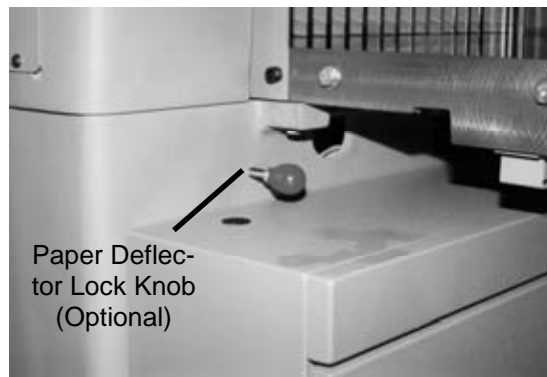

Figure 15

3. Back off the knife adjusting screws on the top of the knife bar, (Figure 16), as far as they will go (counter-clockwise). A new knife will cut deeper than a knife that has been ground several times. If the adjusters are not backed off, damage can result to the new knife and/or the cutting stick.

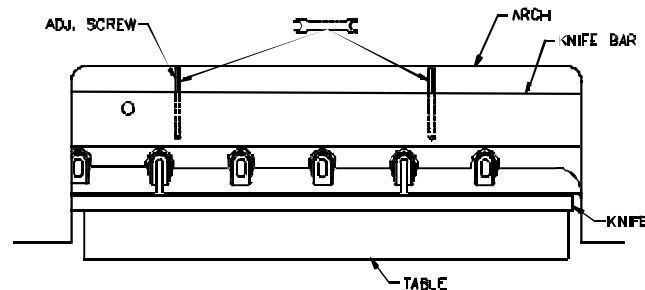

Figure 16

4. Raise the knife.

**X, XG models)** Press Exit. Push both cut buttons, and the knife will return up.

5. **DISCONNECT THE POWER AND LOCK IT OUT**, (See Power Lockout Procedure on pg. 6.)
6. Remove the bolts in the two slotted holes of the knife bar and replace them with the knife lifters. Tighten the lifters enough to hold the blade in place. Remove the remaining four bolts (Figure 17). The leftmost bolt must be removed while the knife bar is "UP".



Figure 17

7. Clear the table and put the empty knife scabbard on the table.

**CAUTION** **DANGER:** Used knives are heavy and still very sharp. Be careful to keep the edge away from your body and keep other people out of the area while handling the blade. Severe lacerations and dismemberment could result from careless handling procedures.

8. Grasp the knife lifters firmly while turning counterclockwise to release the knife from the knife bar. Slowly lower the knife down and to the right. Bring the left side out first and put the blade in the scabbard and secure immediately.
9. Send the dull knife to the grinder.

## 11.2 Knife Installation

1. Use the cutting stick puller, (Figure 18), to remove the cutting stick. Turn the cutting stick to a new surface.



Figure 18

2. Check to make sure the paper deflector is locked down, see Knife Removal, step 2 above. Also check that the knife adjusters have been backed out, (Figure 16 on page 43).
3. Place the new knife scabbard on the cutter table.
4. Remove the knife retainer screws and insert the knife lifters into the knife bolt holes (use the lowest holes) corresponding to the slotted holes in the knife bar. Turn threaded portion of knife lifters into holes in the knife until they contact the scabbard, then back off 1-1/2 turns.

5. Grasp the knife lifters, lift the blade, and insert the blade into the knife bar slot. Slowly guide the blade into the cutter right end first, then bring the left end in parallel to the knife bar. Raise the knife into the knife bar slot as high as it will go. Tighten the lifters to hold the knife.

**NOTE:** If the blade will not go in, either the lifters are screwed into the blade too far or the blade is not centered over the table, and the end of the blade is hitting the end stop in the knife bar.

6. Insert the rest of the knife bolts and washers, snug tighten them, but don't tighten completely. Be sure all bolts have washers. The correct washers are important for proper bolt clearances!
7. Replace the knife lifters with bolts and snug tighten.
8. Place paper across the table to cover the cutting stick.
9. Turn the power ON, lock the knife down (repeat step 1), **and then lock out power** (see page 6).
10. Turn the knife adjusters down, a little at a time (Figure 19), until the blade cuts through the paper evenly, the length of the stick. Be sure the blade is parallel to the cutting stick, or one end may cut deeper than the other, causing uneven wear on the stick.

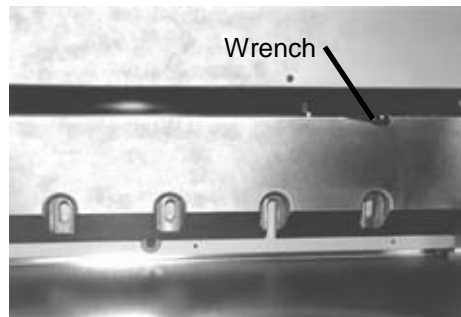

**Figure 19**

11. Tighten all the bolts and release the paper deflector.
12. Turn power on and send the knife to the "UP" position as previously instructed.
13. Make a test cut through a full lift of stock. Make minor adjustments by loosening the bolts and repeating steps 9 through 11.

**NOTE:** If the knife ends cut but the middle does not, you could have dips or uneven spots in either the knife or the cutting stick. These can be eliminated to some extent by laying 1/2" (13mm) strips of paper beneath the cutting stick to shim it up.

### 11.3 Using the Shielded Knife Lifter

There are some differences to be noted for those using the shielded knife lifters as shown in Figure 14 on page 42. When installing the lifter into the knife, use the following procedure.

1. After the scabbard has been placed on the front table and the scabbard screws have been removed, place your fingers along the top edge of the scabbard and your thumbs in the holes in the knife.
2. Pull the knife up in its scabbard until the bevel is exposed.
3. Place the lifter on top of the knife and thread the handles into the knife until they touch the scabbard. Then back the handles off 1/2 turn.
4. Install the knife as described above while using the holes and notches in the shield to see that you are properly aligned. The two center bolts are accessed through holes in the shield. Install the end two bolts, remove the lifter, and install the rest of the bolts. An installed lifter is shown in Figure 20 below.

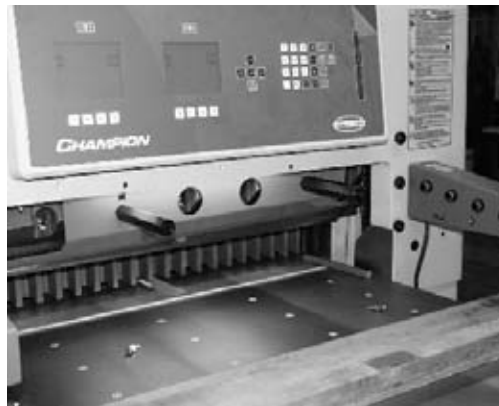

Figure 20

When placing a knife back in its scabbard place the knife and attached lifter on top of the scabbard. Remove the lifter and slide the knife into alignment with the scabbard screw holes. **DO NOT FORGET TO INSTALL THE SCABBARD SCREWS!**

## 11.4 False Clamp Plate

To prevent marking on pressure sensitive jobs, a false clamp plate has been included (installed) with your machine. This plate attaches to the bottom of the clamp. It is secured from the front of the cutter with three set screws.

**CAUTION** ALWAYS disconnect the power and LOCK IT OUT before installing or removing the false clamp plate. NEVER attempt to install or remove the false clamp plate while the machine is running. Remove all tools and stand clear when reconnecting power.

1. *DISCONNECT THE POWER AND LOCK IT OUT!* (See Power Lockout, page 6.)

- Position the false clamp plate under the clamp, (Figure 21). The locator pegs are positioned to the rear of the cutter and are set into holes in the bottom of the clamp.

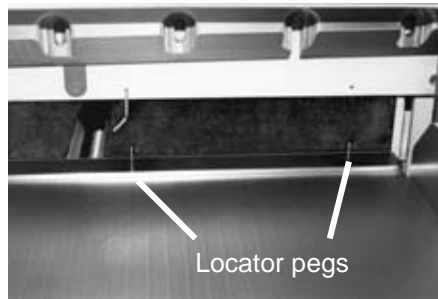

Figure 21

- With a 1/8" Allen wrench, back off the setscrews in front of the clamp and raise the plate up to the bottom of the clamp. It may be necessary to bring the clamp down onto a stack of paper with the foot pedal in order to access the far left setscrew. Raise the false clamp plate evenly or it will have a tendency to bind. When the plate has been raised into position and is flush with the bottom of the clamp, tighten the setscrews to hold the plate in position.
- Make sure that all tools have been taken off the cutter table, reconnect the power, and turn on the power.

NOTE: The cutter cannot be operated closer than 2" (50.8 mm) with the false clamp plate installed.

NOTE: DO NOT ATTEMPT TO OPERATE THE CUTTER UNTIL THE REST OF THIS MANUAL HAS BEEN THOROUGHLY READ AND UNDERSTOOD. CALL YOUR DEALER IF YOU STILL HAVE ANY QUESTIONS.

## 11.5 Knife Care Basics

**! CAUTION ! KNIFE SAFETY !** Knives are **DANGEROUS!!!** They are heavy and very sharp, even after use. Keep the edge away from your body and keep the area clear of others when handling knives. Never touch the cutting edge! To prevent personal injury and damage to the knife, always keep knives in their holders with screws tightened. You are aware of the dangers, but others may not be. Never attempt to hone, polish, or service the knife in any way. Failure to follow safety procedures may result in severe lacerations or dismemberment.

### 11.5.1 Cut Quality

Assuming the proper bevel angle has been chosen for the material being cut, cut quality depends upon blade sharpness and surface finish. Three cut characteristics can indicate a blade needs sharpening:

- Burnishing appears on cut face of lift.
- The cut does not appear straight when viewed from the top.
- The profile of the cut (side view) does not appear to be perpendicular to the table.

Other signs that a knife needs sharpening are:

- The machine seems to strain while cutting. This strain can be heard in the hydraulic motor.
- The knife makes a "rougher" sound as it passes through stock.

- Nicks are visible on the cutting edge of the knife.

## 11.6 Bevel Angle

The most appropriate bevel angle depends upon four factors.

1. The length of time desired between sharpening
2. Physical properties of the stock being cut (hardness, impurities, density)
3. Power output of machine
4. Amount of clamp pressure applied

### 1. Length of Time Between Sharpening

Under identical cutting conditions, knives with larger bevel angles will require sharpening less often than knives with smaller bevel angles. There is more material supporting the cutting edge of larger bevel angles.

### 2. Physical Properties of Stock

In general a smaller bevel achieves a better quality cut. Hard, dense, and impure papers, however, will dull a small angle bevel quickly. Impurities may put nicks on the cutting edge. As a result, cut quality is lost quickly, and knives require sharpening often. Therefore, a larger angle bevel should be chosen for such materials. Soft materials can be cut with small angle bevels without adversely affecting sharpening frequency.

### 3. Power Output of Machine

As the bevel angle increases, more power is required to push the knife through stock. If a bevel angle is too large for a machine, the machine may take excessive wear-and-tear and may stall part way through the cut cycle. Although the knife will require sharpening less often, the machine may incur costly damage.

### 4. Amount of Clamp Pressure Applied

As clamping pressure increases, the pile density increases. As discussed in number 2, above, more dense materials are harder to cut. This presents a dilemma. Higher clamping pressures are used to reduce draw when cutting with large angle bevels. While higher bevel angles increase the lifetime of the knife, high pressure clamping increases the material's density and detracts from knife life. As a result, a compromise must be made between knife life and cut quality.

## 11.7 Helpful Suggestions

- If your shop is large enough to purchase more than one set of knives, the following suggestions may be helpful. A set consists of 3 knives, one in the machine, one back up, and one at the grinder.
- If you cut a variety of stocks (easy and hard to cut), purchase two sets of knives. One set should be beveled at around 21° and the other around 23°.
- Use the smaller angle bevel to cut softer stocks at lower clamping pressures. Begin by cutting the most pure, easy to cut stocks. As the knife dulls, begin cutting the less pure of the softer stocks.
- Use the larger bevel to cut harder more dense stocks at higher clamping pressures. Begin by cutting the softer and most pure of the hard stocks. Then move to cutting the harder and less pure of the hard stocks.

The following suggestions apply to those who can support only one set of knives. The bevel angle on the knives shipped with your machine was chosen for its versatility. It is not the ideal angle for every material, but these suggestions may improve the cut quality for those materials being cut with an inappropriate bevel:

- First, cut the softest, most pure stocks at lower clamping pressures.
- Move to the harder, more pure stocks at higher pressures. You may also need to reduce pile heights.
- Softer, impure stocks are next, followed by the hard impure stocks.

Following these guidelines will decrease the frequency of knife sharpening while maintaining a quality cut as long as possible.

Suggestions for all:

- If the machine seems to strain and cut quality is still good, reduce the pile height. You may also carefully apply glycerin to the bevel when cutting hard, coated stocks. Tie a cloth to the end of a stick; dip the stick in glycerin, and apply. Never apply by hand! In lieu of glycerin you may lightly rub white bar soap along the bevel. Lubrication will prolong the life of your machine and reduce maintenance.
- If the machine seems to strain and cut quality becomes unacceptable, the knife should be changed.
- Typical bevel angles vary from 26° to 19°. The most appropriate general purpose bevel angle (23°) was chosen for your machine. If your most common applications warrant a different angle, careful thought should be given before making the investment.
- Knives should be re-ground to a 32 micro-finish or better.

### 11.8 Knife Care

- To prevent corrosion you received your knife coated with light oil. It should be REMOVED WITH CARE.
- While removing or installing a knife, be careful not to allow the edge to bump against the machine. Nicks will result.
- If a knife bolt is damaged, replace it.
- Always keep knife bolts securely tightened.
- Always use the heavy-duty knife bolt washers provided by Challenge. Failure to do so could result in scratching or marring of the clamp face.
- Store knives in a dry environment to prevent corrosion.
- Never attempt to service a knife in any way.

# 12.0 Lubrication

---

A clean, lubricated machine will cut more accurately, run longer, with less downtime, and fewer repairs.

Schedule lubrication maintenance both early in the day and early in the week. This allows the lubricants to work into the machine. Lubrication at the end of the day or week allows the lubricants to run off without any benefit to the machine.

Clean off dirty, excess grease. Clean accumulated dust off valves, hoses, and connections. Dust build-up increases operating temperatures and causes premature wear of all hydraulic components.

Oil and grease **WEEKLY** as follows.

Run the knife down and **Lockout the Power**, see Power Lockout Procedure, page 6. Most moving parts require lubrication. Remove all panel covers and look for all oil locations (marked with red paint). Make sure oil holes are not plugged and lubricate with a 30 weight oil. See the photos below for critical locations (not all locations are illustrated here). Notice that some are oil locations and some are grease points. Wipe off old and excess grease. Use a National Lubricating Grease Institute No. 1 consistency, extreme pressure grease.

## CAUTION

Replace all guards. Never operate cutter with any guards removed.

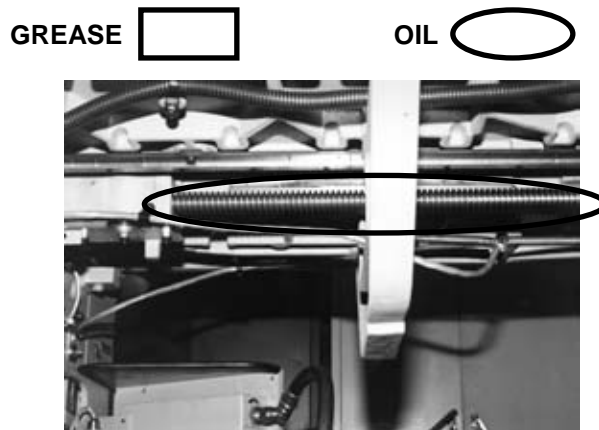

Figure 22



Both Cylinder Pins

Figure 23

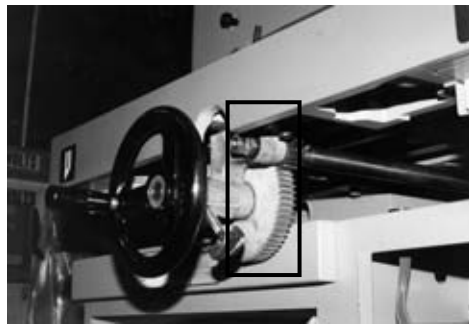

Figure 24

Check bell crank and knife link pin locks to make sure they are in place and secure.

Wipe down the knife bar to remove dust and debris.

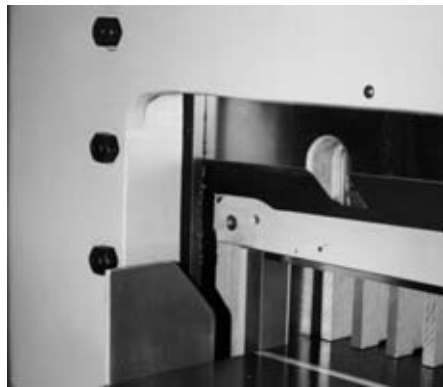

Figure 25



Figure 26

## 12.1 Hydraulic System

The Champion Series Cutters have both hydraulic cutting and hydraulic clamping operation. The cutter is powered by an electric motor coupled directly to a hydraulic pump. The pump has a fixed flow rate output of 5 GPM at 1800 psi (max. system relief setting) at 1800 RPM.

The clamp action is powered by a hydraulic cylinder. When the cut buttons are depressed, this cylinder pulls on the clamp bell crank and brings the clamp down (or brings the clamp up to full hydraulic pressure if the manual foot clamp is down). The cutting action is also powered by a hydraulic cylinder connected directly to the knife bar. The knife sequence valve generates 1600 PSI of back pressure throughout the system to maintain full clamp pressure during the cut. One advantage of the hydraulics is the immediate return of the knife when the cut buttons are released.

The hydraulic fluid should be changed **YEARLY** or EVERY 1000 HOURS of operation.

The oil filter (Challenge part H-227-1) should be changed yearly or whenever any repairs are made to the hydraulic system.

**NOTE:** Failure to change the oil when needed can damage the seals in the clamp and knife cylinders.

Refill the tank with 13.5 gallons of an ISO (International Standards Organization) Viscosity Grade 46, rust, oxidation, and foam inhibiting hydraulic oil. **NOTE: NEVER use Automatic Transmission Oil or Brake Fluid as a substitute for the correct hydraulic fluid.** Dangerous operation conditions could result.

A table of various manufacturers and their equivalents is listed in the Recommended Oils section on page 53.

Check the level of the Hydraulic Reservoir WEEKLY or whenever the machine sounds like it is laboring (this could be due to low oil level). The tank has a sight gauge on the back so you can check the oil level.

## 12.2 Recommended Oils

Use only one of the recommended oils or an ISO VG 46 Hydraulic Fluid equivalent. **Oils other than the recommended type will cause seals, cups, and O-rings to deteriorate. See CAUTION below.**

<u>Oil Name</u>	<u>Distributor</u>
Rykon No. 46	AMOCO
Energol HLP 46	BP
AW Oil 46	Chevron
Pacemaker XD 46	Citgo
Super Hydraulic 46	Conoco
Univis N46	Exxon
Security AW 46	Gulf
Kenoil R&O AW 46	Kendall
DTE 15M	Mobil
Tellus 46	Shell
Rando HDZ 46	Texaco

**⚠ CAUTION** NEVER USE Automatic transmission oil or brake fluid as a substitute! Oils other than the recommended type will cause seals, cups, and O-rings to deteriorate. Unsafe operations conditions will result.

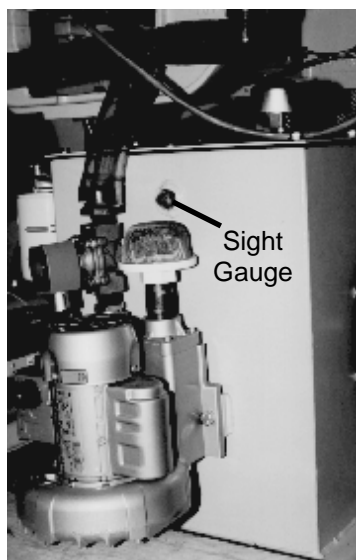

Figure 27

## 12.3 Changing the Oil

**⚠ CAUTION** Only change oil when it is cold. Burns could result from changing oil while it is hot.

Before beginning, you will need (3) empty five gallon buckets, three oil pans or more, a funnel and an assistant. If oil is hot, wait until it cools.

1. Make sure main power to the machine is off.
2. Remove the reservoir tank cover.
3. Using a hand drill and transfer pump commonly found at hardware and home improvement stores, transfer the used oil to empty containers.
4. Remove the magnet stuck to the bottom of the tank. Clean off any debris that may be attached to it.
5. With a clean rag, wipe out any visible debris remaining in the tank.
6. Place the magnet at the location from which it was removed.
7. Replace the oil filter. Place a thin film of new hydraulic oil on the seal of the new filter to insure a proper seal. Firmly hand-tighten the filter onto the filter head.
8. Using the transfer pump, fill the tank with recommended fluid until the level is just above the sight gauge shown in Figure 27 on page 53.
9. Re-install the tank cover with gasket.
10. Before turning on the machine, make sure all hydraulic hose fittings are tight.
11. Turn on main power to the machine. Turn on the hydraulic motor by pressing both cut buttons once. Inspect the hydraulic system for leaks. If leaks are found, turn off main power to the machine and tighten any leaking fittings.

# 13.0 Operator Adjustments/Cleaning

## 13.1 Line Lights

The line light comes on whenever main power is turned to the ON position. The light from each of two bulbs reaches the table after passing between the knife and clamp, (Figure 28).

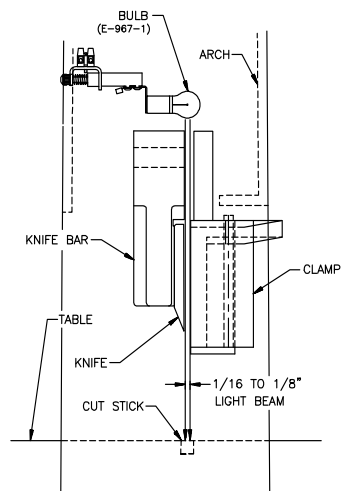

Figure 28

Each light is focused with a socket head cap screw recessed into the arch, directly behind the console, (Figure 29).

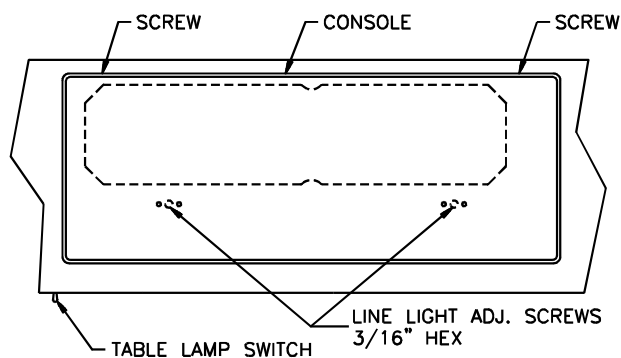

Figure 29

Adjust line:

1. Let the console down by removing the two screws at the top.
2. Place a wide sheet(s) of paper on the cut stick to view the line.
3. Using a 3/16" hex wrench, turn one of the cap screws until you see a 1/16-1/8" beam.

4. Similarly, turn the adjustment screw of the other bulb until one, continuous beam is seen across the cut stick.

Bulb replacement:

1. Make sure the power is OFF and remove key. **DISCONNECT THE POWER AND LOCK IT OUT!** (See Power Lockout procedure, page 6)
2. Lower the console.
3. Remove the old bulb by lightly pushing bulb into the socket and turning it counter-clockwise. **CAUTION!**- If the bulb is still hot, allow a few minutes to cool before changing.
4. Insert the new bulb into the socket and twist clockwise until the bulb locks into place.
5. Reattach the console.
6. Reconnect the power and turn ON.
7. If necessary, adjust the line as above.
8. Unless the cutter will be operated immediately, turn the power off.

## 13.2 Manual Pressure Reducer – (305X Only)

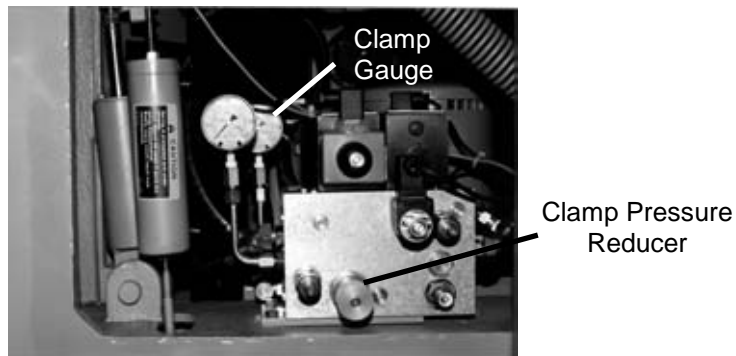

**Figure 30**

This valve limits the amount of pressure to the clamp system. Factory setting: 1000 psi (1400 max/400 min).

To Check:

- With the hydraulic access door open, activate the cut buttons and read the pressure off the clamp gauge (rear gauge). It should read 750 psi for average cutting purposes. For XG models see Operating Instructions.

To Adjust:

1. Loosen the lock knob. There are two knobs, one behind the other, (Figure 30). The outer is the adjusting knob and the inner is the lock knob.
2. Push the cut buttons and check the reading on the clamp gauge when the clamp is on the table and the knife is moving down.

3. Turn the pressure-adjusting knob clockwise for MORE pressure, counterclockwise for LESS.
4. Make another cut and check the pressure gauge. Adjust the pressure to your cuttings needs (see OPERATING TIPS).
5. Tighten the locking knob.

**⚠ CAUTION**

DO NOT set the clamp pressure below 300 psi. Severe lacerations or dismemberment could result! The Knife and Clamp System loses sequence at settings below 300 PSI and the knife could come down before the clamp.

## 13.3 Operator Cleaning

### 13.3.1 Hydraulics

1. The hydraulic fan and tank should be wiped off weekly to maintain maximum cooling of the tank/hydraulic oil.
2. The hydraulic manifold and fittings should be wiped off weekly.

### 13.3.2 Table Conditioning

The table of a paper cutter requires periodic maintenance to remove surface oxidation. Polishing is also required to provide a smooth surface for paper to move freely. The frequency of this maintenance will be determined by a number of factors. Among these are the humidity, environmental dust, handprints, liquid spills, and type of paper stock. We recommend the use of the **Challenge Cutter Care Kit P/N 16077** for of your table care needs.

To prepare a new machine's table, follow the procedure below:

1. Remove the rust-protective coating from the table with a solvent.
2. Remove all solvent residue from the table with a dry cloth. Continue until the cloth shows no sign of residue.
3. Apply a light coating of an SAE 10-weight non-detergent motor oil or equivalent to the table and allow it to penetrate for at least one hour.
4. Remove all excess oil from the table with paper toweling (not cloth) until the paper towel you are using shows no sign of oil.
5. Apply a paste wax (Challenge P/N 16078) to the table to seal the pores of the metal.
6. Note: Do not use a wax that contains a cleaning compound on the table. The cleaner contains microscopic abrasive particles that will cause wear between the table and the bottom of the backgauge. A silicone spray (Challenge P/N 16079) will show the same type of wear as the cleaner if the excess silicone is not removed. If the excess is not removed, the silicone spray has a substance that holds the silicone to the surface it is sprayed on that causes a black, gummy build-up under the backgauge. If a silicone spray is used, paper toweling must be used to remove the excess to prevent this wear and build-up.

To clean surface oxidation from a table, follow the procedure below:

1. Spray "Rust-B-Gone" (Challenge P/N 16080) on the table and allow it to dissolve the rust. Then remove it with paper toweling. Or, pour a small quantity of SAE 10-weight motor oil onto the table. Using a Scotch-Brite Pad or a 400 grit sand paper, polish the table following the "grain" of the metal until all oxidation is removed to your satisfaction.

2. Remove all of the oil from the table until the cloth you are using shows no sign of residue.
3. Apply a light coating of an SAE 10-weight non-detergent motor oil or equivalent to the table and allow it to penetrate for at least one hour.
4. Remove all excess oil from the table with paper toweling (not cloth) until the paper towel you are using shows no sign of oil.
5. Apply a paste wax (Challenge P/N 16078) to the table to seal the pores of the metal.
6. Note: Do not use a wax that contains a cleaning compound on the table. The cleaner contains microscopic abrasive particles that will cause wear between the table and the bottom of the backgauge. A silicone spray (Challenge P/N 16079) will show the same type of wear as the cleaner if the excess silicone is not removed. If the excess is not removed, the silicone spray has a substance that holds the silicone to the surface it is sprayed on that causes a black, gummy build-up under the backgauge. If a silicone spray is used, paper toweling must be used to remove the excess to prevent this wear and build-up.

### 13.3.3 Console

- The console should be cleaned with a mild water based detergent applied to a damp cloth or paper towel. Petroleum based solvents will damage the console.

### 13.3.4 Machine Base

1. The machine base should be cleaned with a mild, water based detergent applied to a damp cloth.
2. Always be careful when cleaning around safety warning labels. Use limited amounts of cleaners in those areas.

# 14.0 Program Log

It is always good practice to keep written records of important repeat jobs. In case a channel or the entire memory is accidentally lost. Important jobs will not have to be reprogrammed from scratch. Photocopy this page as needed to build a program log.

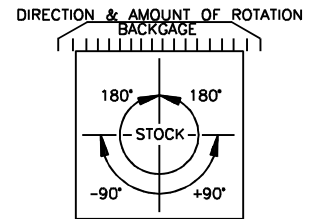

CHANNEL \_\_\_\_\_  
PAGE \_\_\_\_\_ OF \_\_\_\_\_

JOB/DESCRIPTION \_\_\_\_\_

STEP	CUT POSITION	ROTATE
01		
02		
03		
04		
05		
06		
07		
08		
09		
10		
11		
12		
13		
14		
15		
16		
17		
18		
19		
20		
21		
22		
23		
24		
25		
26		
27		
28		
29		
30		
31		
32		
33		
34		
35		

STEP	CUT POSITION	ROTATE
36		
37		
38		
39		
40		
41		
42		
43		
44		
45		
46		
47		
48		
49		
50		
51		
52		
53		
54		
55		
56		
57		
58		
59		
60		
61		
62		
63		
64		
65		
66		
67		
68		
69		
70		

# 15.0 Channel Log

---

It is recommended that you keep an abbreviated Channel Log and detailed Program Logs (copy this form) for important or repeat jobs. In the event memory capacity is reached, a glance at the Channel Log will tell you which channels may be cleared to make more room.

CHAN.	JOB/CUSTOMER	SAVE
01		
02		
03		
04		
05		
06		
07		
08		
09		
10		
11		
12		
13		
14		
15		
16		
17		
18		
19		
20		
21		
22		
23		
24		
25		
26		
27		
28		
29		
30		
31		
32		
33		
34		
35		

CHAN.	JOB/CUSTOMER	SAVE
36		
37		
38		
39		
40		
41		
42		
43		
44		
45		
46		
47		
48		
49		
50		
51		
52		
53		
54		
55		
56		
57		
58		
59		
60		
61		
62		
63		
64		
65		
66		
67		
68		
69		
70		

# 16.0 Safety System Tests

Machine manufacturer CHALLENGE Model \_\_\_\_\_

Serial Number \_\_\_\_\_

Frequency of test: **THESE TESTS SHOULD BE PERFORMED AT THE BEGINNING OF EACH WORK DAY.**

Turn on the cutter and start the hydraulic motor (see operator's manual for instructions). Enable the electric eye safety system.

Test #1: Using a 12 mm wide test piece, check the object detection capability of the electric eye system. Do this by waving the test piece throughout the electric eye beam area. The steady green and steady orange lights on the emitter side (RH) should change to steady red and flashing orange.

Test #2: Press both cut buttons to begin a cut cycle. During the downward motion of the knife or clamp, lean into the path of the electric eye beams. The downward motion of the knife and clamp should stop immediately, and the knife and clamp should return to the up position.

If the machine fails either test, DO NOT use machine. Repair or adjust is necessary.

Please enter date and initials for both tests (make copies of this form if necessary).

Date \_\_\_\_\_

Test 1 \_\_\_\_\_

Test 2 \_\_\_\_\_

Date \_\_\_\_\_

Test 1 \_\_\_\_\_

Test 2 \_\_\_\_\_

Date \_\_\_\_\_

Test 1 \_\_\_\_\_

Test 2 \_\_\_\_\_

Repairs	Initials of Repairer	Date
_____	_____	_____
_____	_____	_____
_____	_____	_____
_____	_____	_____
_____	_____	_____
_____	_____	_____
_____	_____	_____

